

# PCI-1202/1602/1800/1802

## Hardware User's Manual

### **Warranty**

All products manufactured by ICP DAS are warranted against defective materials for a period of one year from the date of delivery to the original purchaser.

### **Warning**

ICP DAS assume no liability for damages consequent to the use of this product. ICP DAS reserves the right to change this manual at any time without notice. The information furnished by ICP DAS is believed to be accurate and reliable. However, no responsibility is assumed by ICP DAS for its use, nor for any infringements of patents or other rights of third parties resulting from its use.

### **Copyright**

Copyright © 1998~1999 by ICP DAS. All rights are reserved.

### **Trademark**

The names used for identification only maybe registered trademarks of their respective companies.

---

Table of Contents

<b>1. INTRODUCTION</b>	<b>4</b>
1.1 GENERAL DESCRIPTION	4
1.2 THE BLOCK DIAGRAMS	5
1.3 FEATURES	6
1.4 SPECIFICATIONS	7
1.5 APPLICATIONS	13
1.6 PRODUCT CHECK LIST	13
<b>2. HARDWARE CONFIGURATION</b>	<b>14</b>
2.1 BOARD LAYOUT	14
2.2 JUMPER SETTING	17
2.3 DAUGHTER BOARDS	18
2.4 ANALOG INPUT SIGNAL CONNECTION	22
2.5 THE CONNECTORS	26
<b>3. I/O CONTROL REGISTER</b>	<b>29</b>
3.1 HOW TO FIND THE I/O ADDRESS	29
3.2 THE ASSIGNMENT OF I/O ADDRESS	30
3.3 THE I/O ADDRESS MAP	30
3.4 SECTION 1: PCI CONTROLLER	32
3.5 SECTION 2: TIMER CONTROL	33
3.6 SECTION 3: CONTROL REGISTER	36
3.7 SECTION 4: D/I/O REGISTER	59
3.8 SECTION 5: A/D & D/A REGISTER	60
<b>4. A/D CONVERSION OPERATION</b>	<b>62</b>
4.1 THE CONFIGURATION CODE TABLE	62
4.2 THE UNIPOLAR/BIPOLAR	63
4.3 THE INPUT SIGNAL RANGE	63
4.4 THE SETTLING TIME	64
4.5 HOW TO DELAY THE SETTLING TIME	64
4.6 THE AD CONVERSION MODE	65
4.7 THE FIXED-CHANNEL MODE AD CONVERSION	67
4.8 THE MAGICSCAN MODE AD CONVERSION	68
<b>5. M_FUNCTION</b>	<b>77</b>
5.1 INTRODUCTION	78

---

<b>6. CONTINUOUS CAPTURE FUNCTIONS .....</b>	<b>82</b>
6.1 GENERAL PURPOSE DRIVER .....	82
6.2 SAVE DATA IN PC MEMORY DRIVER.....	86
<b>7. CALIBRATION.....</b>	<b>88</b>
7.1 AD CALIBRATION .....	88
7.2 D/A CALIBRATION .....	90
<b>8. SOFTWARE AND DEMO PROGRAM.....</b>	<b>92</b>
<b>9. DIAGNOSTIC PROGRAM .....</b>	<b>94</b>
9.1 POWER-ON PLUG&PLAY TEST .....	94
9.2 DRIVER PLUG&PLAY TEST.....	94
9.3 D/O TEST.....	95
9.4 D/A TEST.....	95
9.5 A/D TEST.....	95
<b>10. PERFORMANCE EVALUATION .....</b>	<b>96</b>

# 1. Introduction

---

## 1.1 General Description

The PCI-1800<sub>(H/L)</sub> and PCI-1802<sub>(H/L)</sub> are high performance, multifunction analog, digital I/O board for PC and compatible computers in a 5V PCI slot. This series features a **continuous, 330K samples/second, gap-free** data acquisition under DOS, Windows 95/98 and Windows NT 3.51/4.0. This family has the same features: one 12-bit 330K AD converter, two 12-bit independent DA converter, 16 channels TTL compatible DI and 16 channels TTL compatible DO. The 1800H/L provides 16 channels single-ended or 8 channel differential inputs. The 1802H/L provides 32 channels single-ended or 16 differential inputs. The letter 'L' denotes the low gain and the 'H' denotes the high gain. Two DACs of this multifunction card are independent bipolar voltage output with jumper selectable voltage output range. The AD scan function of 1800 series is very amazing, we call it "**MagicScan**". It scans with two modes: **the fix channel mode** and **the channel scan mode**, both mode can be up to 330K samples per second. We also provide three trigger mode for this series: software trigger, pacer trigger and external trigger, each trigger modes use "**MagicScan**" to perform the data acquisition. The external trigger can be programmed to one of the three trigger method : pre-trigger, post-trigger and middle-trigger. The PCI-1800/1802 fully supports "Plug and Play" under Windows 95/98.

The PCI-1202<sub>(H/L)</sub> is very similar to PCI-1802<sub>(H/L)</sub>. The different items between the PCI-1802 and **PCI-1202** are given as follows:

- A/D sampling rate is **110K samples/second**
- FIFO size is **1K words**

The PCI-1602 is very similar to PCI-1802L. The different items between the PCI-1802 and **PCI-1602** are given as follows:

- A/D is **16-bit**
- A/D sampling rate is **200K samples/second for PCI-1602F**
- A/D sampling rate is **100K samples/second for PCI-1602**

## 1.2 The Block Diagrams

The block diagram of PCI-1202/1602/1800/1802 is given as follows:

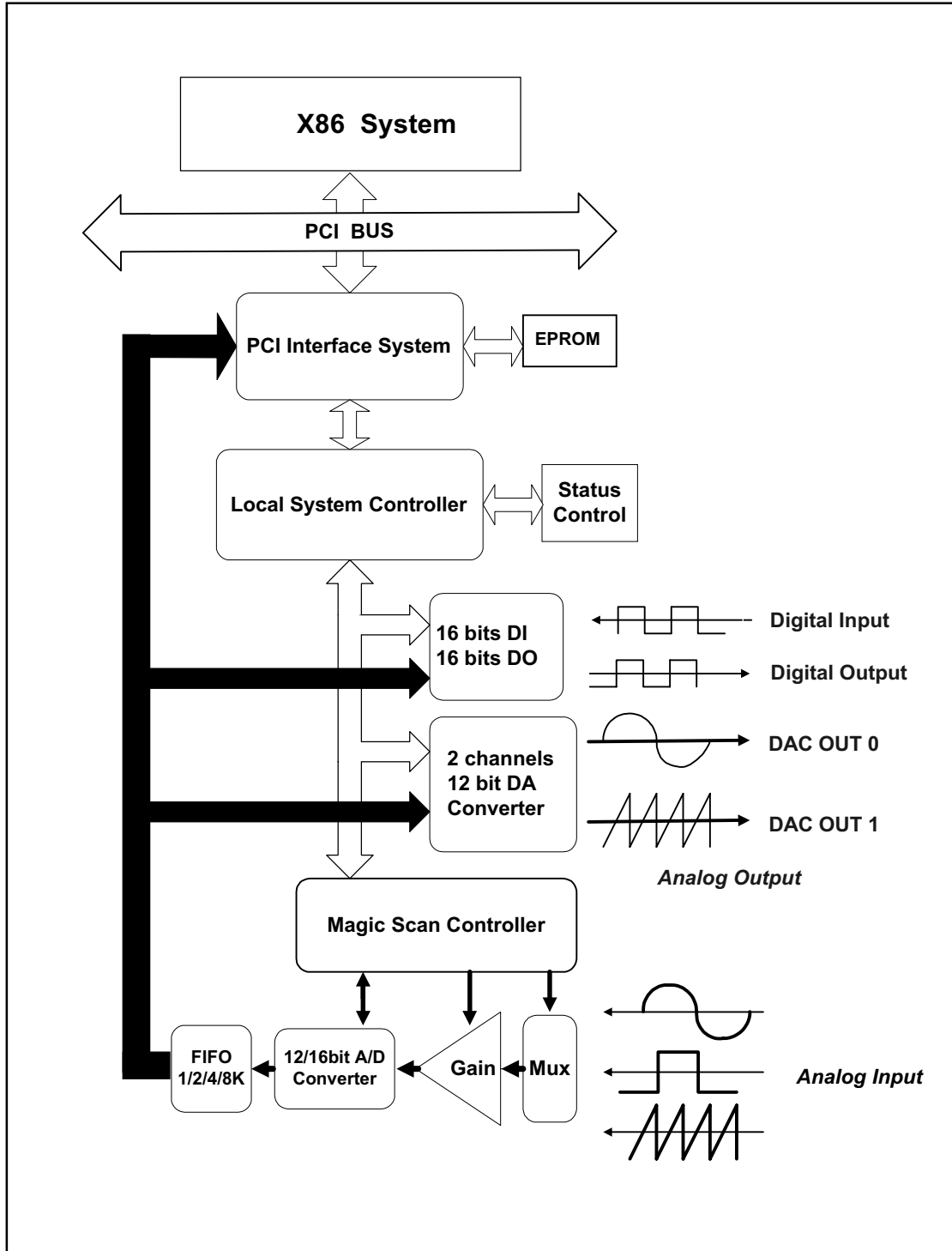


Figure 1-1. The block diagram of PCI-1202/1602/1800/1802.

## 1.3 Features

The general features of PCI-1202/1602/1800/1802 series are given as follows:

- Bus: 5V PCI ( Peripherals Component Interface) bus.
  
- A/D:
  1. PCI-1800(H/L)/1802(H/L) : A/D converter = 330K samples/second  
PCI-1602F: A/D converter = 200K samples/second  
PCI-1602: A/D converter = 100K samples/second  
PCI-1202(H/L): A/D converter = 110K samples/second
  2. 32 single-ended / 16 differential analog inputs for PCI-1202/1602/1802 H/L.
  3. Three different A/D triggers: software, pacer and external trigger
  4. Provides three different external triggers: pre-trigger, middle-trigger and post-trigger
  5. Programmable input signal configuration.
  6. Provides “**MagicScan**” function
  7. FIFO: 1K for PCI-1202(H/L)/1800(H/L)  
2K for PCI-1802(H/L)  
8K for PCI-1602, PCI-1602F, PCI-1800(H/L) and PCI-1802(H/L)
  
- D/A:
  1. Two channels independent 12 bits DACs.
  2. Bipolar voltage output with +/-5V or +/- 10V jumper selectable.
  3. High throughput: refer to chapter 10.
  
- DIO:
  1. 16 channels TTL compatible DI and 16 channels TTL compatible DO .
  2. High speed data transfer rate: refer to chapter 10.
  
- Timer:
  1. Three 16-bits timer/counter (8254).
  2. Timer 0 is used as the internal A/D pacer trigger timer.
  3. Timer 1 is used as the external trigger timer.
  4. Timer 2 is used as the machine independent timer for settling time delay.

## 1.4 Specifications

---

### 1.4.1 Power Consumption:

- +5V @960mA maximum, PCI-1202/1602/1800/1802.
  - Operating temperature : 0°C ~ +70°C
- 

### 1.4.2 Analog Inputs

- Channels: ( software programmable )
    1. PCI-1202/1602/1802: 32-single-ended/16-differential inputs, jumper select.
    2. PCI-1800: 16-single-ended/8-differential inputs, jumper select.
  - Gain control: ( software programmable )
    1. PCI-1202/1800/1802 H: 0.5, 1, 5, 10, 50, 100, 500, 1000.
    2. PCI-1202/1800/1802 L: 0.5, 1, 2, 4, 8.
    3. PCI-1602/1602F: 1,2,4,8.
  - Bipolar input signal range :
    1. PCI-1202/1800/1802 L:  $\pm 10V, \pm 5V, \pm 2.5V, \pm 1.25V, \pm 0.0625V$ .
    2. PCI-1202/1800/1802 H:  $\pm 10V, \pm 5V, \pm 1V, \pm 0.5V, \pm 0.1V, \pm 0.05V, \pm 0.01V, \pm 0.005V$ .
    3. PCI-1602/1602F:  $\pm 10V, \pm 5V, \pm 2.5V, \pm 1.25V$
  - Unipolar input signal range :
    1. PCI-1202/1800/1802 L: 0~10V, 0~5V, 0~2.5V, 0~1.25.V.
    2. PCI-1202/1800/1802 H: 0~10V, 0~1V, 0~0.1V, 0~0.01V
  - Input current : 250 nA max (125 nA typical ) at 25 °C.
  - Over voltage : continuous single channel to **70Vp-p**
  - Input impedance :
    - PCI-1202/1800/1802 H:  $10^{10}\Omega // 6pF$
    - PCI-1202/1602/1800/1802 L:  $10^{13}\Omega // 1pF$
-

### 1.4.3 A/D Converter

- Resolution: 12-bit for PCI-1202/1800/1802 H/L  
16-bit for PCI-1602/1602F
- Conversion Cycle: 330K s/s for PCI-1800/1802 H/L  
200K s/s for PCI-1602F  
100K s/s for PCI-1602  
110K s/s for PCI-1202 H/L
- Internal sample and hold.
- 12-bit ADC Input Voltages and Output Codes for PCI-1202/1800/1802 H/L

Analog Input	Digital Output Binary Code	Hex Code
	MSB <span style="float: right;">LSB</span>	
+9.995V	0111 1111 1111	7FF
0V	0000 0000 0000	000
-4.88mv	1111 1111 1111	FFF
-10V	1000 0000 0000	800

- 16-bit ADC Input Voltages and Output Codes for PCI-1602/1602F

Analog Input	Digital Output Binary Code	Hex Code
	MSB <span style="float: right;">LSB</span>	
+99.9V	0111 1111 1111 1111	7FFF
+0V	0000 0000 0000 0000	0000
-305μV	1111 1111 1111 1111	FFFF
-10V	1000 0000 0000 0000	8000



## 1.4.4 A/D Trigger Methods

- Trigger modes:
  1. Internal software trigger
  2. Internal pacer trigger
  3. External trigger: pre-trigger, middle-trigger and post-trigger

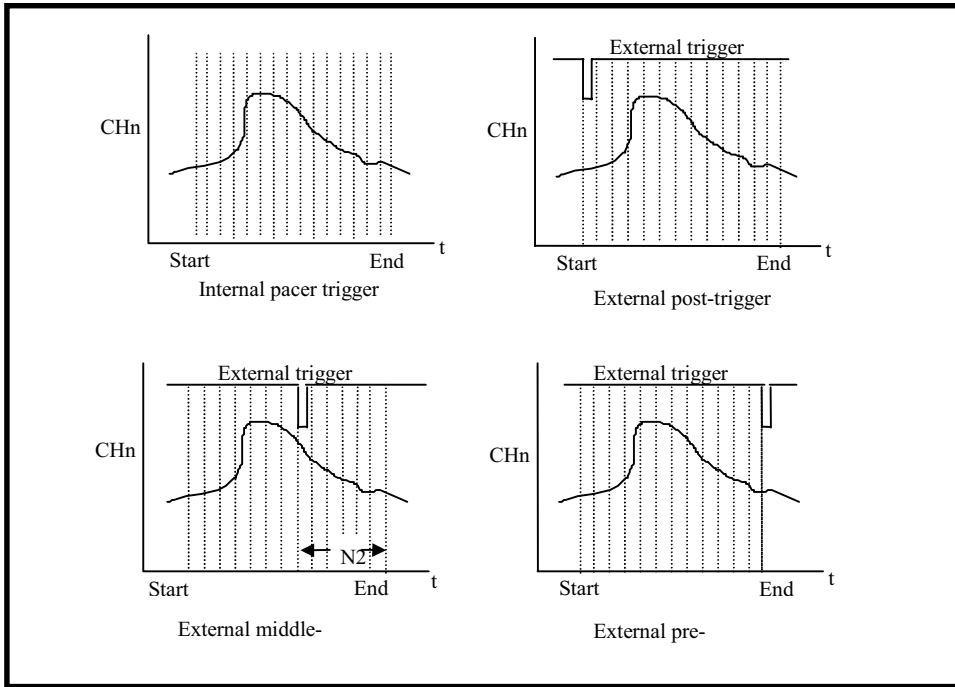


Figure. 1-2. Trigger modes of PCI-1202/1602/1800/1802.

## 1.4.5 A/D Throughput

- Throughput of PCI-1800L/1802L

Gains	Bipolar(V)	Unipolar(V)	Throughput
0.5	±10V	0~10V	333K s/s
1	±5V	0~10V	333K s/s
2	±2.5V	0~5V	333K s/s
4	±1.25V	0~2.5V	333K s/s
8	±0.625V	0~1.25V	333K s/s

- Throughput of PCI-1602F/1602

Gains	Bipolar(V)	Throughput	Throughput
1	±10V	200K s/s	100K s/s
2	±5V	200K s/s	100K s/s
4	±2.5V	200K s/s	100K s/s
8	±1.25V	200K s/s	100K s/s

- Throughput of PCI-1202L

Gains	Bipolar(V)	Unipolar(V)	Throughput
0.5	±10V	0~10V	110K s/s
1	±5V	0~10V	110K s/s
2	±2.5V	0~5V	110K s/s
4	±1.25V	0~2.5V	110K s/s
8	±0.625V	0~1.25V	110K s/s

- Throughput of PCI-1202H/1800H/1802H

Gains	Bipolar(V)	Unipolar(V)	Throughput
0.5/1	±10/±5V	0~10V	40K s/s
5/10	±1/±0.5V	0~1V	40K s/s
50/100	±0.1/±0.05V	0~0.1V	10K s/s
500/1000	±0.01/±0.005V	0~0.01V	1K s/s

## 1.4.6 D/A Converter

- Channels: 2 independent.
- DAC Type: 12-bit multiplying DA converter.
- Accuracy :  $\pm 1$  bit.
- Output type: 12-bit double buffered
  
- Output range: -5~+5V or -10~+10V jumper select.
- Output drive:  $\pm 5$ mA
- Settling time: 0.4  $\mu$ s (typical) to 0.01% for full scale step.
- Data transfer rate: 2.1M words/second (non-burst mode).
  
- 12- bit DAC output code for PCI-1202/1602/1800/1802 H/L

Data Input			Analog Output
MSB		LSB	
1111	1111	1111	+Vref (2047/2048)
1000	0000	0001	+Vref (1/2048)
1000	0000	0000	0 Volts
0111	1111	1111	-Vref (1/2048)
0000	0000	0000	-Vref (2048/2048)

## 1.4.7 Digital I/O

- Output port: 16-bit, TTL compatible
- Input port: 16-bit, TTL compatible
- Throughput: 2.1M word/sec ( non-burst mode ).

---

## 1.4.8 Interrupt Channel

- Interrupt: Automatically assigned by ROM BIOS.
- Enable/Disable: Via on-board control register.

---

## 1.4.9 Programmable Timer/Counter

- Type: 82C54 programmable timer/counter
- Timers: three 16-bit independent timer
  1. Timer 0 is used as the internal A/D pacer trigger timer.
  2. Timer 1 is used as the external trigger A/D pacer timer.
  3. Timer 2 is used as the machine independent timer.
- Input clock: 8 M Hz.

## 1.5 Applications

- Signal analysis.
- FFT & frequency analysis.
- Transient analysis.
- Speech analysis.
- Temperature monitor.
- Production test.
- Process control.
- Vibration analysis.
- Energy management.
- Other industrial and laboratory measurement and control.

---

## 1.6 Product Check List

In addition to this manual, the package includes the follows items:

- PCI-1202/1602/1800/1802 H/L multifunction card.
- One NAPPPI/dos CD-ROM or diskette.
- Software User's Manual

It's recommended to read the release note first. All important information will be given in release notes as follows:

1. Where you can find the software driver & utility
2. How to install software & utility
3. Where is the diagnostic program
4. FAQ

### **Attention !**

If any of these items is missing or damaged, please contact your local agent. Save the shipping materials and carton in case you want to ship or store the product in the future.

## 2. Hardware Configuration

### 2.1 Board Layout

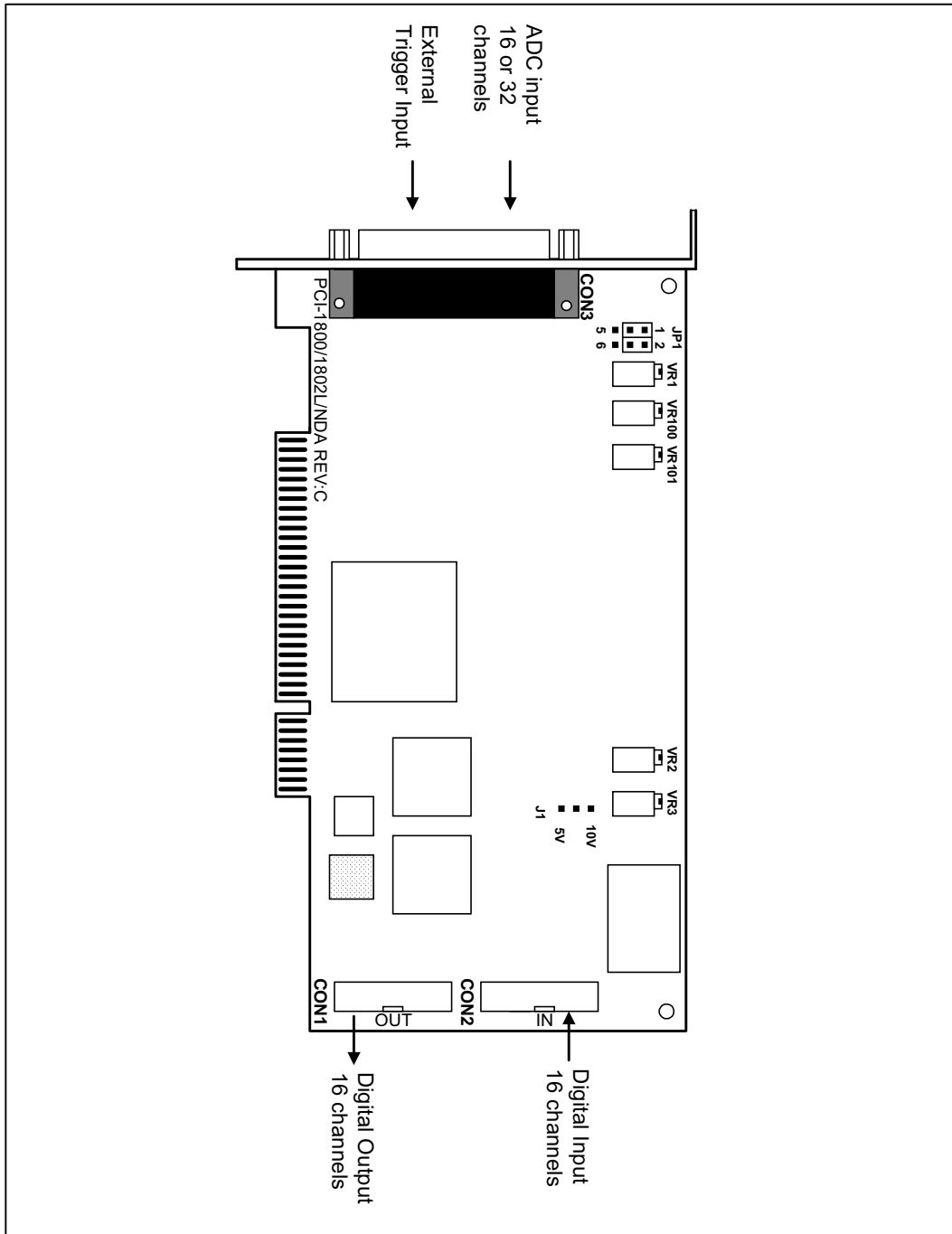


Figure 2-1. PCI-180X(H/L)/NDA board layout.

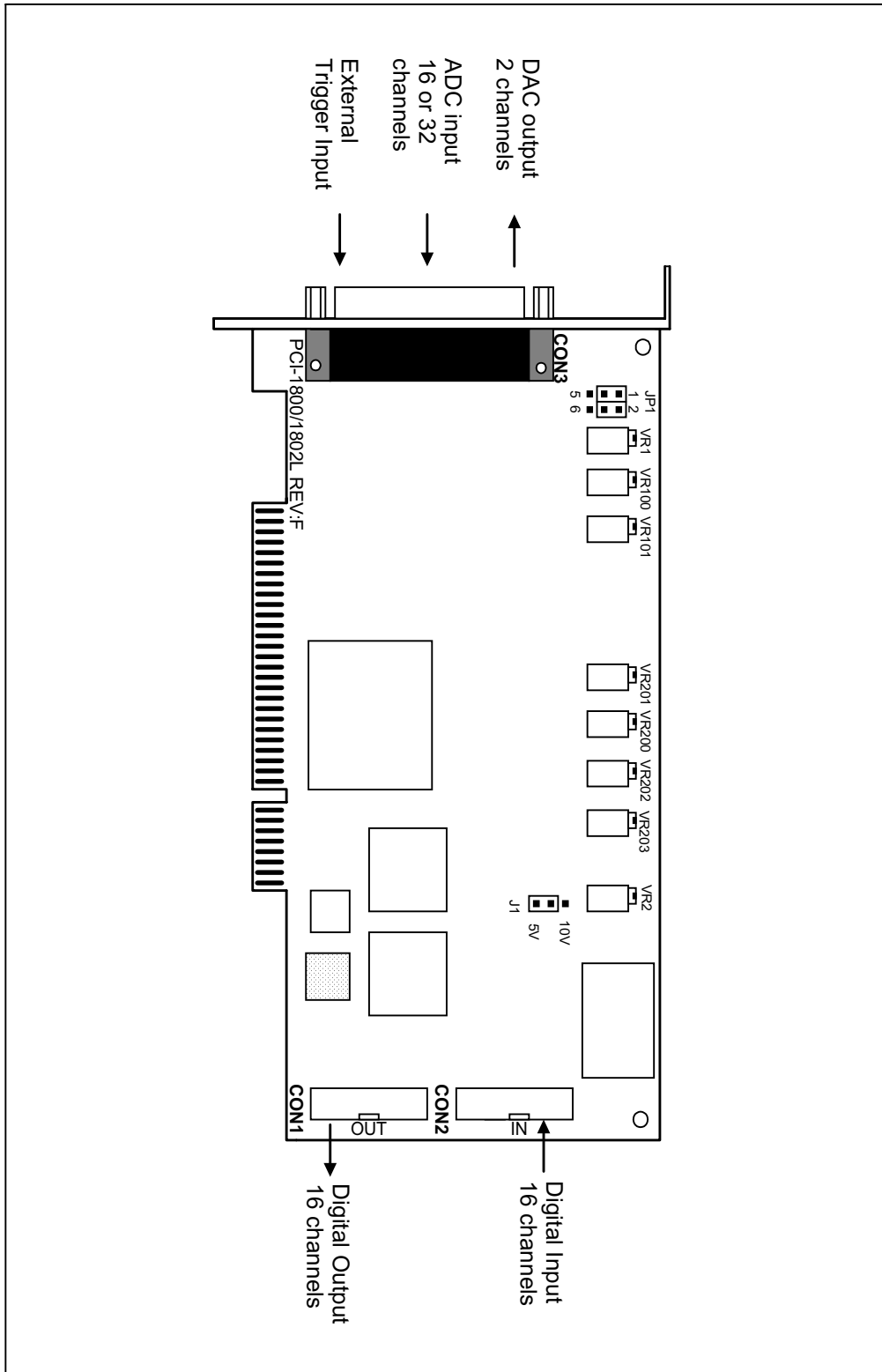


Figure 2-2. PCI-1202(H/L)/1800(H/L)/1802(H/L) board layout.

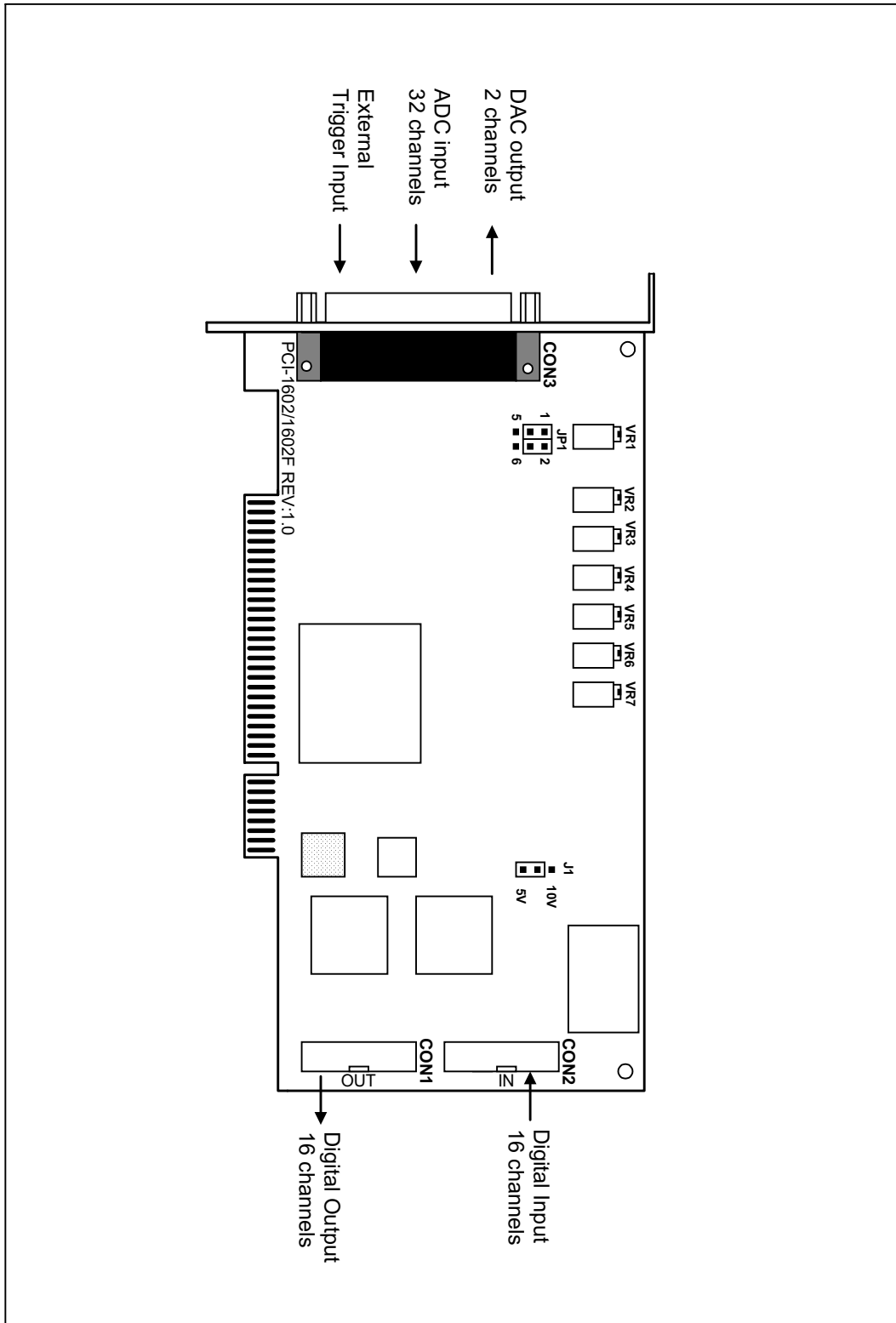


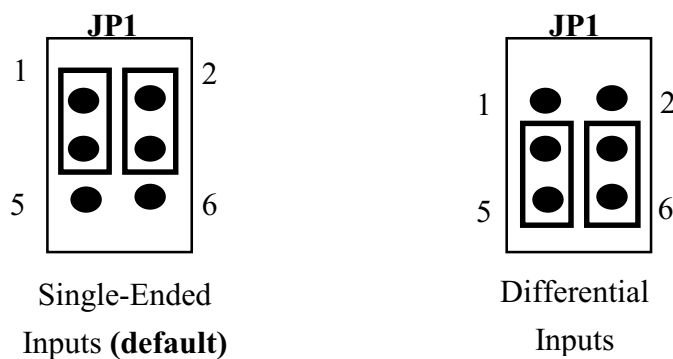
Figure 2-3. PCI-1602/1602F board layout.



## 2.2 Jumper Setting

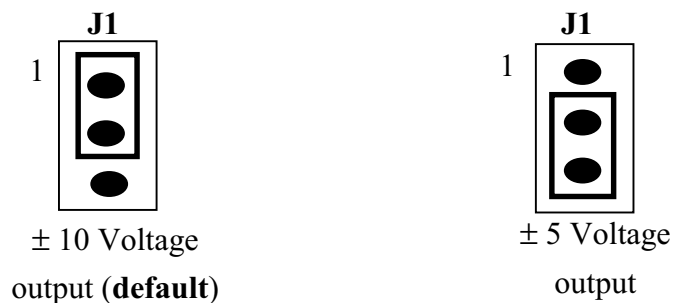
### 2.2.1 JP1 : A/D Input Type Selection

This jumper is used to select the analog input type. For single-ended inputs, the use should connect pin1,3 and pin2,4. For differential inputs, pin3,5 and pin4,6 should be connected.



### 2.2.2 J1 : D/A Reference Voltage Selection

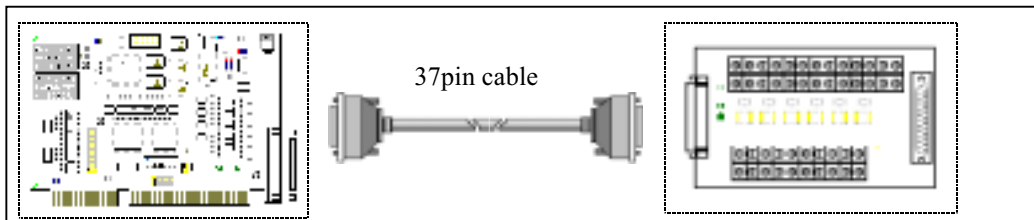
J1 is used to select the internal D/A output reference voltage. To select the  $\pm 10V$  voltage output, the pin 1&2 should be connected. To select the  $\pm 5V$  voltage output, the pin 2&3 should be connected.



## 2.3 Daughter Boards

### 2.3.1 DB1825

The DB-1825 is a daughter board designed for 32 channels AD cards such as ISO\_AD32, PCI-1202/1602/1802. Refer to Appendix A for “DB-1825 user manual” .



---

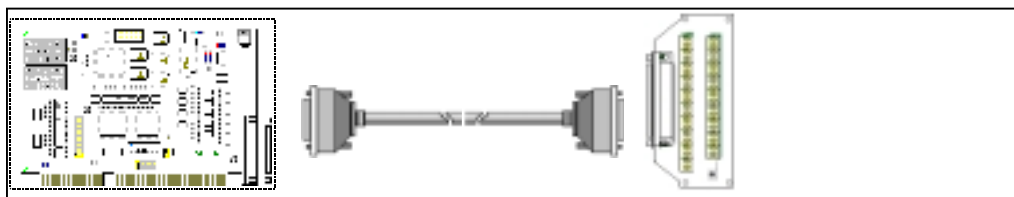
### 2.3.2 DB-8225

The DB-8225 provides a **on-board CJC**(Cold Junction Compensation) circuit for thermocouple measurement and **terminal block** for easy signal connection and measurement. The CJC is connected to A/D channel\_0. The PCI-1800 can connect CON3 direct to DB-8225 through a 37-pin D-sub connector. Refer to “DB-8225 User Manual” for details.

---

### 2.3.3 DB37

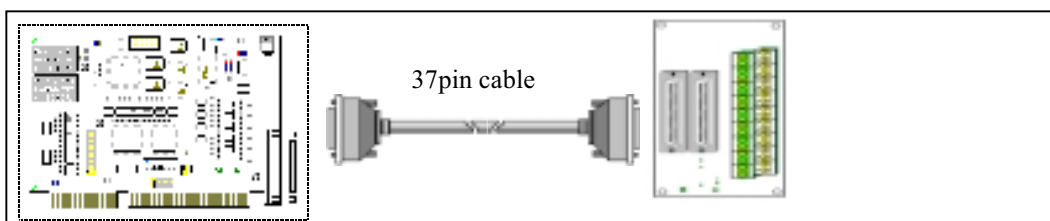
The DB-37 is a general purpose daughter board for D-sub 37 pins. It is designed for easy wire connection.



---

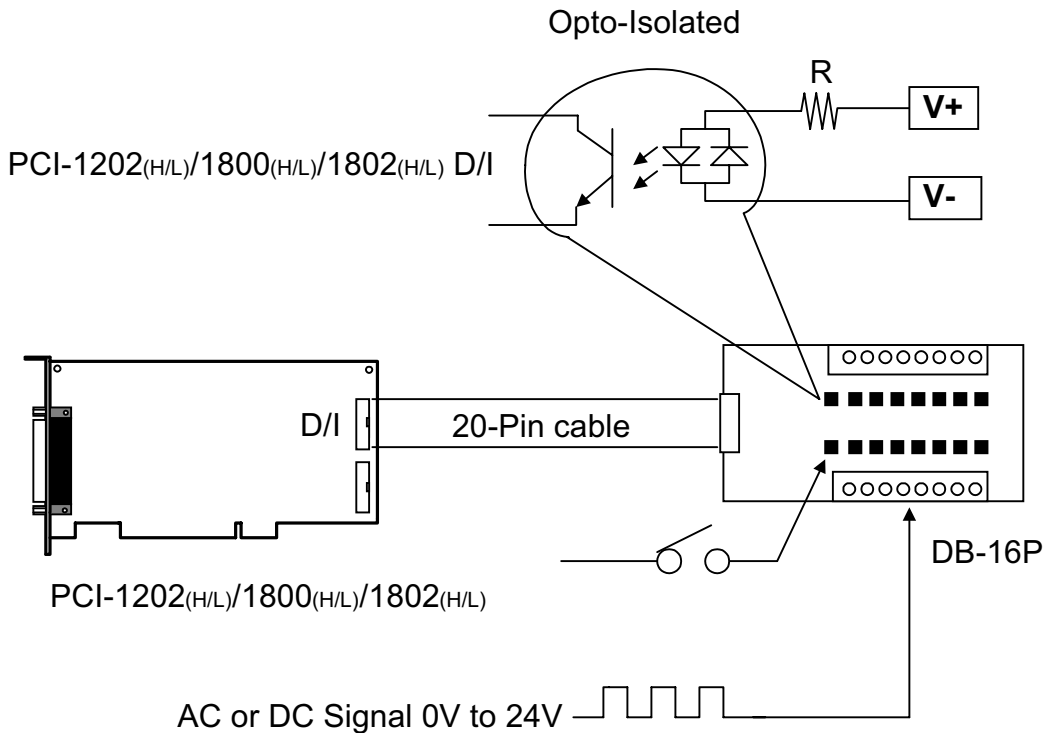
### 2.3.4 DN37

The DN-37 is a general purpose daughter board for DIN Rail Mounting. It is designed for easy wire connection. It is Din-Rail mounting.



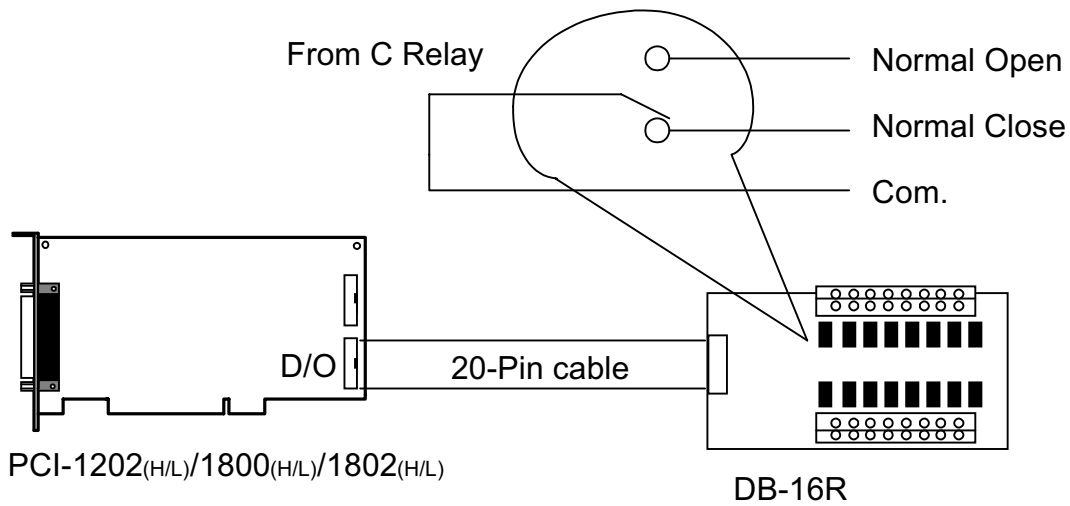
## 2.3.5 DB-16P Isolated Input Board

The DB-16P is a 16-channel isolated digital input daughter board. The optically isolated inputs of the DB-16P consists of a bi-directional optocoupler with a resistor for current sensing. You can use the DB-16P to sense DC signal from TTL levels up to 24V or use the DB-16P to sense a wide range of AC signals. You can use this board to isolated the computer from large common-mode voltage, ground loops and transient voltage spike that often occur in industrial environments.



## 2.3.6 DB-16R Relay Board

The DB-16R, 16-channel relay output board, consists of 16 from C relays for efficient switch of load by programmed control. It is connector and functionally compatible with 785 series board but with industrial type terminal block. The relay are energized by apply 5 voltage signal to the appropriated relay channel on the 20-pin flat connector. There are 16 enunciator LEDs for each relay, light when their associated relay is activated. To avoid overloading your PC' s power supply, this board provides a screw terminal for external power supply.

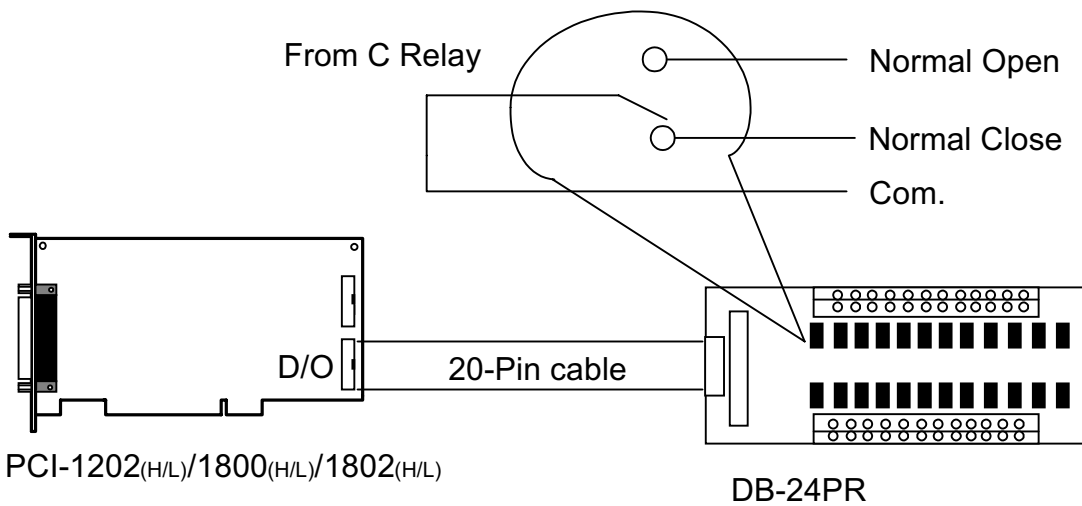


Note: Channel: 16 From C Relay

Relay: Switching up to 0.5A at 110ACV or 1A at 24 DCV

## 2.3.7 DB-24PR Power Relay Board

The DB-24PR, 24-channel power relay output board, consists of 8 form C and 16 form A electromechanical relays for efficient switching of load programmed control. The contact of each relay can control a 5A load at 250ACV/30VDCV. The relay is energized by applying a 5 voltage signal to the appropriate relay channel on the 20-pin flat cable connector(just used 16 relays) or 50-pin flat cable connector.(OPTO-22 compatible, for DIO-24 series). Twenty - four enunciator LEDs, one for each relay, light when their associated relay is activated. To avoid overloading your PC' s power supply , this board needs a +12VDC or +24VDC external power supply.



Note: 50-Pin connector(OPTO-22 compatible), for DIO-24, DIO-48, DIO-144  
 20-Pin connector for 16 channel digital output, A-82X, A-62X, DIO-64, ISO-DA16/DA8  
 Channel: 16 From A Relay , 8 From C Relay  
 Relay: Switching up to 5A at 110ACV / 5A at 30DCV

## 2.4 Analog Input Signal Connection

The PCI-1202/1602/1800/1802 can measure single-ended or differential type analog input signal. Some analog signal can be measured in single-end or differential mode, but some analog signal only can be measured in one of the single-ended or differential mode. The user must decide which mode is suitable for measurement.

In general, there are 4 different analog signal connection method as shown in Figure 2-4 to Figure 2-7. The Figure 2-4 is suitable for grounding source analog input signals. The Figure 2-5 is used to measure more channels than in the Figure 2-4 but only suitable for large analog input signals. The Figure 2-6 is suitable for thermocouple and the Figure 2-7 is suitable for floating source analog input signals. **Note : In Figure 2-6, the maximum common mode voltage between the analog input source and the AGND is 70Vp-p, so the user must take care that the input signal is under specification first. If the common mode voltage is over 70Vp-p, the input multiplexer will be damaged forever.**

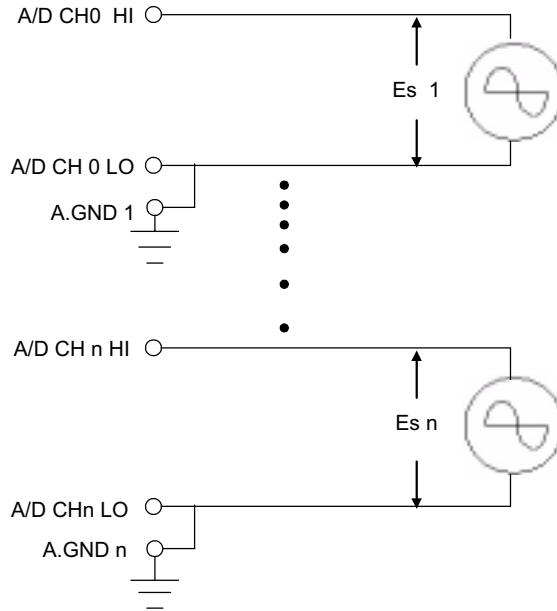
The simple way to select the input signal connection configuration is as below.

- 1. Grounding source input signal → select Figure 2-4**
- 2. Thermocouple input signal → select Figure 2-6**
- 3. Floating source input signal → select Figure 2-7**
- 4. If  $V_{in} > 0.1V$  and  $gain \leq 10$  and need more channels → select Figure 2-5**

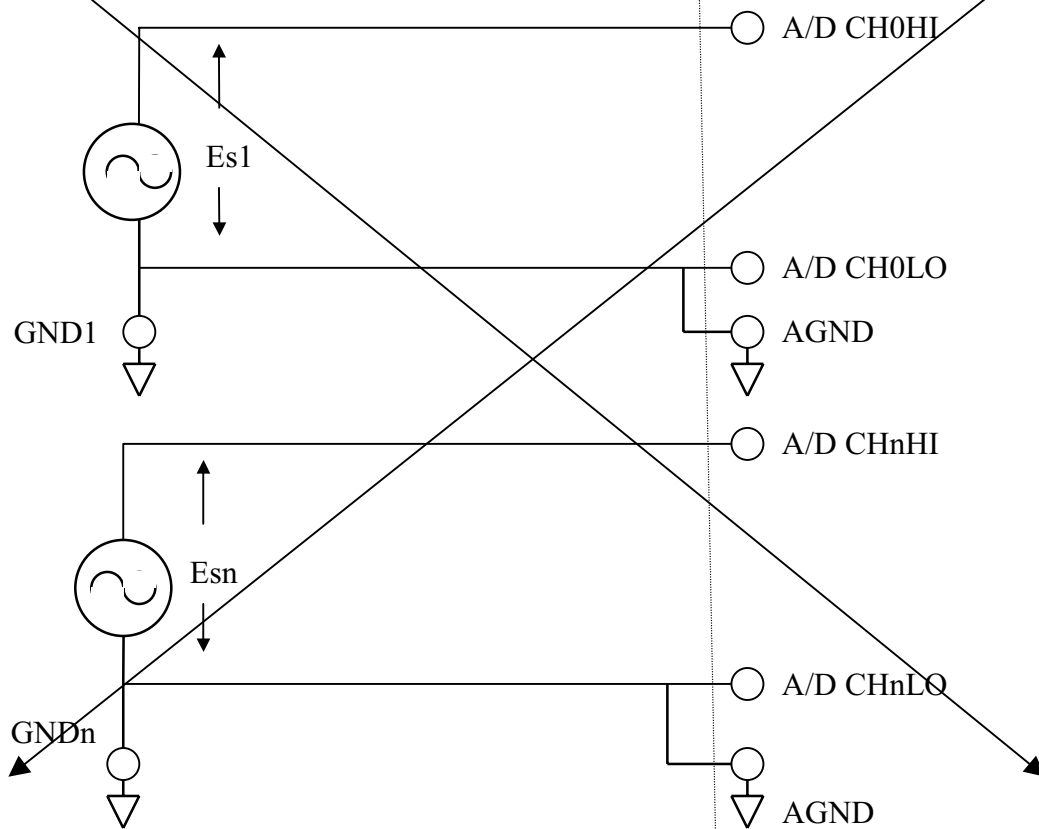
If the user can not make sure the characteristic of input signal, the test steps are given as below:

- 1. Step1 : try Figure 2-4 and record the measurement result**
- 2. Step2 : try Figure 2-7 and record the measurement result**
- 3. Step3 : try Figure 2-5 and record the measurement result**
- 4. Compare the measurement result of step1,step2,step3 and select the best one**

**Figure 2-4. Connecting to grounding source input (Right way)**

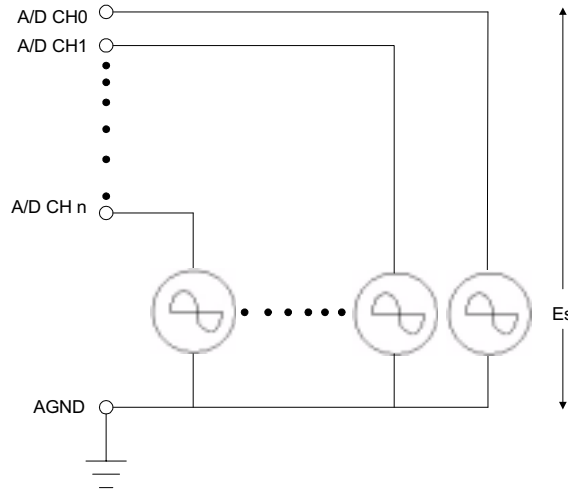


**Figure 2-4. Wrong way**



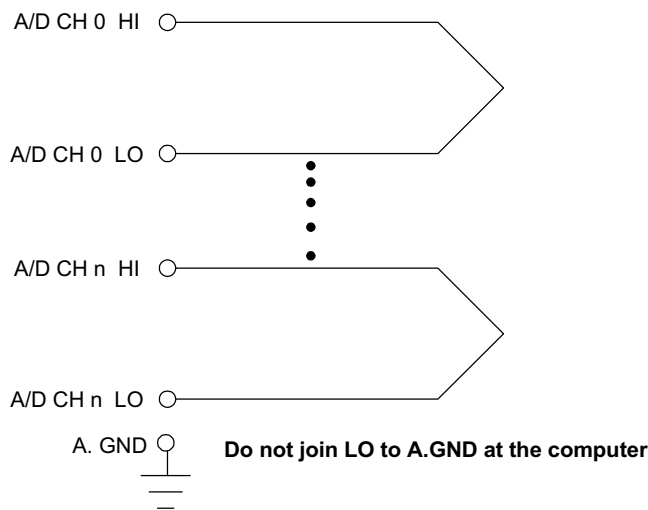
**Figure 2-5. Connecting to singled-ended input configuration**

PCI-1202/1602/1800/1802



**Figure 2-6. connecting to thermocouple configuration**

PCI-1202/1602/1800/1802



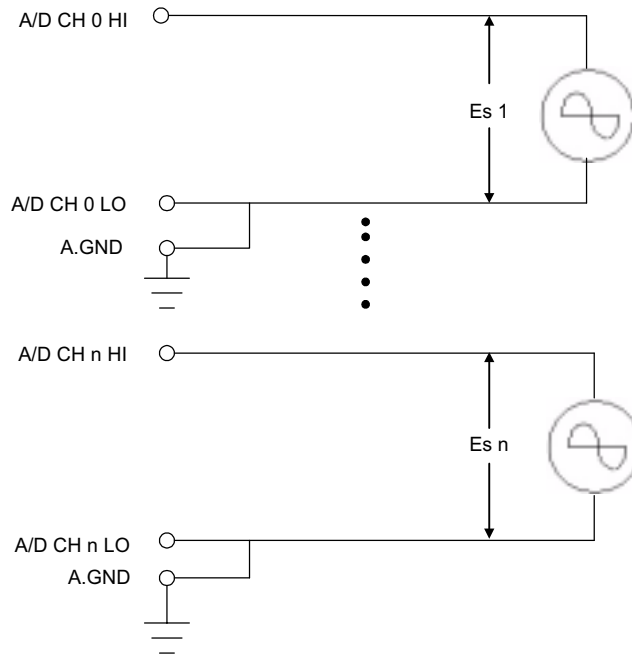
Note : If the input signal is not thermocouple, the user should use oscilloscope to measure common mode voltage of  $V_{in}$  before connecting to PCI-1202/1602/1800/1802. Don't use voltage meter or multimeter.

**CAUTION:** In Figure 2-6, the maximum common mode voltage between the analog input source and the AGND is 70Vp-p, so the user must make sure that the input signal is under specification first. If the common mode voltage is over 70Vp-p, the input multiplexer will be damaged forever.



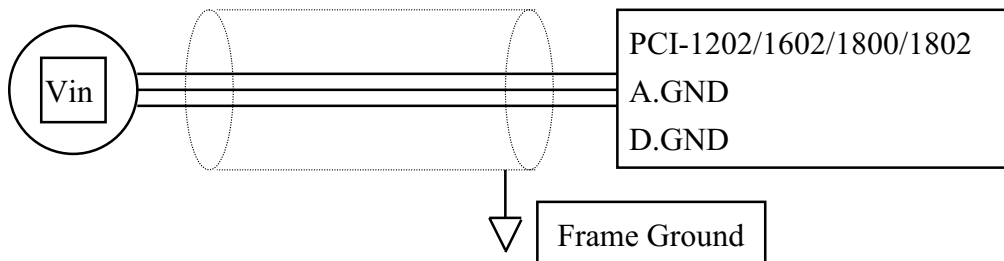
**Figure 2-7. connecting to floating source configuration**

PCI-1202/1602/1800/1802



## Signal Shielding

- Signal shielding connections in Figure 2-4 to Figure 2-7 are all the same
- Use single-point connection to **frame ground (not A.GND or D.GND)**



## 2.5 The Connectors

CON1: Pin assignment of the digital output connector.

Pin	Name	Pin	Name
1	Digital output 0	2	Digital output 1
3	Digital output 2	4	Digital output 3
5	Digital output 4	6	Digital output 5
17	Digital output 6	8	Digital output 7
9	Digital output 8	10	Digital output 9
11	Digital output 10	12	Digital output 11
13	Digital output 12	14	Digital output 13
15	Digital output 14	16	Digital output 15
17	PCB ground	18	PCB ground
19	PCB +5V	20	PCB +12V

CON2: Pin assignment of digital input connector.

Pin	Name	Pin	Name
1	Digital input 0	2	Digital input 1
3	Digital input 2	4	Digital input 3
5	Digital input 4	6	Digital input 5
7	Digital input 6	8	Digital input 7
9	Digital input 8	10	Digital input 9
11	Digital input 10	12	Digital input 11
13	Digital input 12	14	Digital input 13
15	Digital input 14	16	Digital input 15
17	PCB ground	18	PCB ground
19	PCB +5V	20	PCB +12V

CON3: pin assignment of single-ended/differential input.(for PCI-1202/1602/1802H/L)

Pin	Name	Pin	Name
1	Analog input 0/0+	20	Analog input 16/0-
2	Analog input 1/1+	21	Analog input 17/1-
3	Analog input 2/2+	22	Analog input 18/2-
4	Analog input 3/3+	23	Analog input 19/3-
5	Analog input 4/4+	24	Analog input 20/4-
6	Analog input 5/5+	25	Analog input 21/5-
7	Analog input 6/6+	26	Analog input 22/6-
8	Analog input 7/7+	27	Analog input 23/7-
9	Analog input 8/8+	28	Analog input 24/8-
10	Analog input 9/9+	29	Analog input 25/9-
11	Analog input 10/10+	30	Analog input 26/10-
12	Analog input 11/11+	31	Analog input 27/11-
13	Analog input 12/12+	32	Analog input 28/12-
14	Analog input 13/13+	33	Analog input 29/13-
15	Analog input 14/14+	34	Analog input 30/14-
16	Analog input 15/15+	35	Analog input 31/15-
17	Analog ground	36	Analog output 1
18	Analog output 0	37	Digital ground
19	External trigger		

CON3: pin assignment of single-ended/differential input.(for PCI-1800H/L)

Pin	Name	Pin	Name
1	Analog input 0/0+	20	Analog input 8/0-
2	Analog input 1/1+	21	Analog input 9/1-
3	Analog input 2/2+	22	Analog input 10/2-
4	Analog input 3/3+	23	Analog input 11/3-
5	Analog input 4/4+	24	Analog input 12/4-
6	Analog input 5/5+	25	Analog input 13/5-
7	Analog input 6/6+	26	Analog input 14/6-
8	Analog input 7/7+	27	Analog input 15/7-
9	Analog Ground	28	Analog Ground
10	Analog Ground	29	Analog Ground
11	N.C.	30	Analog output 0
12	N.C.	31	N.C.
13	PCB +12V	32	Analog output 1
14	Analog Ground	33	N.C.
15	Digital Ground	34	N.C.
16	N.C.	35	N.C.
17	External Trigger	36	N.C.
18	N.C.	37	N.C.
19	PCB +5V		

N.C. : Abbreviation of “ Not Connected “.

## 3. I/O Control Register

### 3.1 How to Find the I/O Address

The plug&play BIOS will assign a proper I/O address to every PCI-1800/1802 card in the power-on stage. The P180X\_DriverInit(..) can detect how many PCI-1800/1802 cards in the system. Then the P180X\_DriverInit(..) will detect the I/O address of these cards. The P180X\_DriverInit(..) is supported in NAPPCI/dos, NAPPCI/w31, NAPPCI/w95 and NAPPCI/wnt. The P180X\_DriverInit(..) is implemented based on the PCI plug&play mechanism-2. The P180X\_DriverInit(..) must be called once before all the other driver is called. The function of P180X\_DriverInit(..) are given as follows:

1. Detect how many PCI-1800/1802 cards in the system ?
2. Detect and save the I/O control address of every PCI-1800/1802 card

The sample program source is given as follows:

```
wRetVal=P180X_DriverInit(&wBoards);    /* call P180X_DriverInit(..) first */
printf("Threr are %d P180X Cards in this PC\n",wBoards);

/* dump every P180X card's configuration address space */
printf("The Configuration Space -> Timer Control DIO AD/DA \n");
for (i=0; i<wBoards; i++)
{
    printf("Card %02d: %04xH %04xH %04xH %04xH\n", i,wConfigSpace[i][0],
        wConfigSpace[i][1], wConfigSpace[i][2],wConfigSpace[i][3]);
}

/* The P180X_ActiveBoard() function must be used to active a board, */
/* then all operation will take effect to the active board. */
printf("Now Active First P180X Card...\n");
P180X_ActiveBoard( 0 );
```

- P1202\_DriverInit(...) is designed for PCI-1202H/L
- P1602\_DriverInit(...) is designed for PCI-1602 and PCI-1602F

## 3.2 The Assignment of I/O Address

The plug&play BIOS will assign the proper I/O address to PCI-1202/1602/1800/1802. If there is only one PCI-1202/1602/1800/1802, the user can identify the board\_1. If there are two PCI-1202/1602/1800/1802 cards in the system, the user will be very difficult to identify which board is board\_1. The software driver can support 16 boards max. Therefore the user can install 16 boards of PCI-1202/1602/1800/1802 in one PC system. How to find board\_2 ?

**The simplest way to find the board number is to use DEMO15.EXE given in DOS demo program.** This demo program will send to D/O and read back from D/I. If the user install a 20-pin flat cable between CON1 & CON2, the value read from D/I will be the same as D/O. The operation steps are given as follows:

1. Remove all 20-pin flat cable between CON1 and CON2
2. Install all PCI-1202/1602/1800/1802 cards into the PC system
3. Power-on and run DEMO15.EXE
4. Now all D/I value will be different from D/O value
5. Install a 20-pin flat cable into CON1 & CON2 of any PCI-1202/1602/1800/1802 card
6. There will be one card's D/I value = D/O value, the card number is also shown in screen

**Therefore the user can find the card number very easy if he install a 20-pin flat cable into PCI-1202/1602/1800/1802 one-by-one.**

---

## 3.3 The I/O Address Map

The I/O address of PCI-1202/1602/1800/1802 is automatically assigned by the main board ROM BIOS. The I/O address can also be reassigned by user. **It is strongly recommended not to change the I/O address by user. The plug&play BIOS will assign proper I/O address to each PCI-1202/1602/1800/1802 very well.** There are five sections of I/O address used by this card and each section can be assigned to an unused I/O space. The hardware I/O ports are described as follows:

Section	Address	Name	Operation	Access
1	Section1 + 0h	PCI controller add-on mail box	W	32-bits
	Section1 + 38h	PCI interrupt control register	R/W	32bits
	Section1 + 3Ch (or 3Eh, 3Fh)	On board NV-RAM access control register	R/W	32 bits (8 bits)
2	Section2 + 00h	8254 timer1	R/W	8/16/32 bits
	Section2 + 04h	8254 timer2	R/W	8/16/32 bits
	Section2 + 08h	8254 timer3	R/W	8/16/32 bits
	Section2 + 0Ch	8254 control	W	8/16/32 bits
3	Section3 +00h	Control register	W	16/32 bits
	Section3 + 00h	Status register	R	8/16/32 bits
	Section3 + 04h	A/D software trigger	W	8/16/32 bits
4	Section4 + 00h	DI port	R	16 bits
	Section4 + 00h	DO port	W	16 bits
5	Section5 + 00h	A/D data port	R	16 bits
	Section5 + 00h	D/A channel 1.	W	16 bits
	Section5 + 04h	D/A channel 2.	W	16 bits

The driver name of these address are given as follows:

section_2 : wAddrTimer	→ save in wConfigSpace[Board][0]
section_3 : wAddrCtrl	→ save in wConfigSpace[Board][1]
section_4 : wAddrDio	→ save in wConfigSpace[Board][2]
section_5 : wAddrAdda	→ save in wConfigSpace[Board][3]

## 3.4 Section 1: PCI Controller

Although 64 I/O ports are used by on-board PCI-controller, only 3 registers can be directly used by user.

Address		Access	Functions	Operation
+ 0		Write only (32 bit)	Out-going mail-box	Write a 0 to wait for add-on interrupt.
+38		Write (32bit)	Enable/Re-enable/ Disable target interrupt	<ol style="list-style-type: none"> <li>1. Enable : Write 00010010h to this port.</li> <li>2. Re-enable: Write 00010010h to this port.</li> <li>3. Disable : Write 0 to this port.</li> </ol>
		Read (32bit)	Read interrupt status.	Bit 16 : 1 → interrupt generated. 0 → no interrupt.
+3C (32bit)	+3F (8bits)	Write (8bit)	Write command to nvRAM control register	0x80 : load low address 0xA0: load high address 0xC0: begin write. 0xE0: begin read.
		Read (8bit)	Read status from nvRAM control register	Bit 7 : 1 → busy 0 → ready
	+3E (8bits)	Write (8bit)	Write nvRAM address or nvRAM data to register.	After finish writing to nvRAM control register, write data to this port.
Read (8bit)		Read nvRAM data from this register.	After finish writing to nvRAM control register, read data from this port..	

The user does not have to know about these registers in the normal condition. Refer to “AMCC S5933 PCI Controllers User Manual” for all registers details.



## 3.5 Section 2: Timer Control

The timer-0 is used as the internal trigger A/D pacer timer. The timer-1 is designed for the external trigger pacer timer. The timer-2 is used as the machine independent timer. **The timer-2 is very important for settling time delay.** Refer to Intel's "Microsystem Components Handbook" for 8254 programming. The block diagram of the 8254 timer is given as follows:

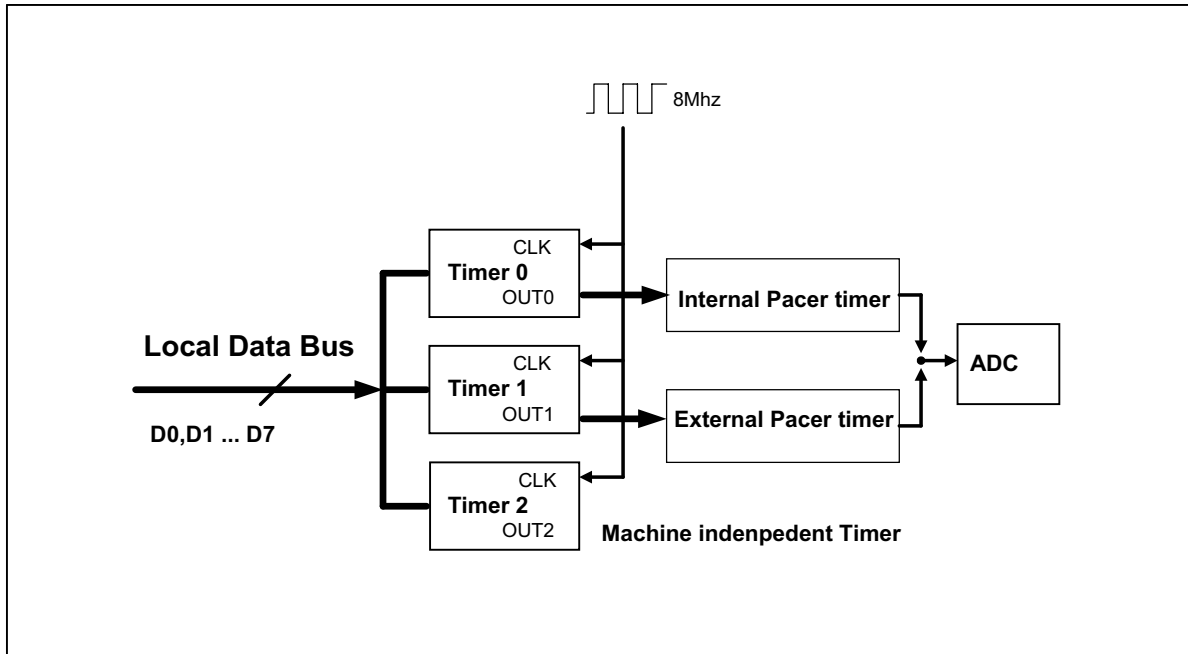


Figure 3-1: The block diagram of PCI-1202/1602/1800/1802 8254 timer.

The I/O address of 8254 timer is given as follows:

- I/O address of timer/counter\_0 =  $wAddrTimer+0*4$
- I/O address of timer/counter\_1 =  $wAddrTimer+1*4$
- I/O address of timer/counter\_2 =  $wAddrTimer+2*4$
- I/O address of control register =  $wAddrTimer+3*4$

## **// timer0 → for pacer trigger**

```
void enable_timer0(WORD divv) // for internal pacer trigger
{
  output((WORD)(wAddrTimer+3*4), 0x34); /* enable pacer timer_0 */
  output((WORD)(wAddrTimer+0*4), (WORD)(divv & 0xff));
  output((WORD)(wAddrTimer+0*4), (WORD)((divv>>8) & 0xff));
}

void disable_timer0(void)
{
  output((WORD)(wAddrTimer+3*4), 0x34); /* disable pacer timer_0 */
  output((WORD)(wAddrTimer+0*4), 0x01);
  output((WORD)(wAddrTimer+0*4), 0x00);
}
```

## **// timer1 → for external trigger**

```
void enable_timer1(WORD divv) /* for external trigger pacer timer */
{
  output((WORD)(wAddrTimer+3*4), 0x74); /* enable pacer timer_1 */
  output((WORD)(wAddrTimer+1*4), (WORD)(divv & 0xff));
  output((WORD)(wAddrTimer+1*4), (WORD)((divv>>8) & 0xff));
}

void disable_timer1(void)
{
  output((WORD)(wAddrTimer+3*4), 0x74); /* disable timer_1 */
  output((WORD)(wAddrTimer+1*4), 0x01);
  output((WORD)(wAddrTimer+1*4), 0x00);
}
```

---

**// timer2 → for Machine Independent Timer**

```

/* address of timer 2 = wAddrTimer+2*4
   address of ctrl    = wAddrTimer+3*4
   input clock       = 8M
   down count 8 time = 1 us
   down count 65536/8 = 8192 uS --> max 8191 uS
*/
WORD P180X_DelayUs(WORD wDelayUs)
{
WORD wDownCount,wLow,wHigh,wVal;
double fTimeOut;

if (wDelayUs>=8191) return(InvalidateDelay);
wDownCount=wDelayUs*8;
wLow=wDownCount&0xff;
wHigh=(wDownCount>>8)&0xff;
outport((wAddrTimer+3*4), 0xb0);      /* timer_2 mode_0 0xb0 */
outport((wAddrTimer+2*4), wLow);
outport((wAddrTimer+2*4), wHigh);

fTimeOut=1.0; // wait 1 to stop
for (;;)
{
wVal=inport(wAddrCtrl)&0x01;
if (wVal!=0) return(NoError);      /* if the timer is up, this bit will be 0 */
fTimeOut+=1.0;
if (fTimeOut>6553500.0)
return(DelayTimeOut);
}
}

```

- P1202\_DelayUs(...) is designed for PCI-1202H/L
- P1602\_DelayUs(...) is designed for PCI-1602 and PCI-1602F

## 3.6 Section 3: Control Register

- I/O address of control register = wAddrCtrl + 0\*4
- I/O address of status register = wAddrCtrl + 0\*4
- I/O address of trigger register = wAddrCtrl + 1\*4

The flow path of analog input signal is given as follows:

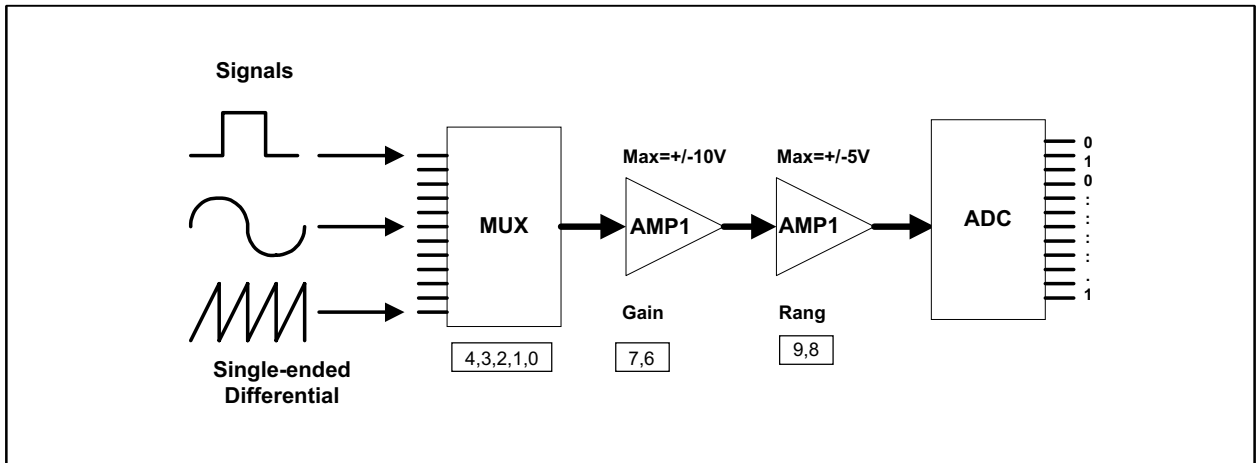


Figure 3-2: The flow path of Analog input signal.

### 3.6.1 The control register

The format of the control register is given as follows:

B15	B14	B13	B12 ~ B10	B9, B8	B7, B6	B5	B4 ~ B0
-----	-----	-----	-----------	--------	--------	----	---------

- B4~ B0: A/D channel select
- B7, B6: A/D gain control.
- B9, B8: A/D input range control.
- B12~B10: external trigger control.
- B13: handshake control to MagicScan controller.
- B15: clear FIFO.
- B5, B14: reserved

### 3.6.1.1 Bit4~ Bit0: A/D channel select

A/D channel	B3	B2	B2	B1	B0	
0	0	0	0	0	0	1800/1202/1602/1802
15	0	0	0	0	0	1800/1202/1602/1802
16	1	0	0	0	0	1202/1602/1802
31	1	1	1	1	1	1202/1602/1802

---

### 3.6.1.2 Gain control

[B7, B6]	PCI-1XXXL	PCI-1XXXH
[0, 0]	PGA=1	PGA=1
[0, 1]	PGA=2	PGA=10
[1, 0]	PGA=4	PGA=100
[1, 1]	PGA=8	PGA=1000

---

### 3.6.1.3 Input range control

[B9, B8]	Output
[0, 0]	PGA
[1, 0]	PGA-5
[0, 1]	PGA/2
[1, 1]	PGA/2 - 5

### 3.6.1.4 Configuration Table

The configuration table of PCI-1202L/1800/1802L is given as follows:

Bipolar/Unipolar	Input Signal Range	Gain	Settling Time	[B9,B8,B7,B6]
Bipolar	+/- 5V	1	3 us	0000
Bipolar	+/- 2.5V	2	3 us	0001
Bipolar	+/- 1.25V	4	3 us	0010
Bipolar	+/- 0.625V	8	3 us	0011
Bipolar	+/- 10V	0.5	3 us	0100
Bipolar	+/- 5V	1	3 us	0101
Bipolar	+/- 2.5V	2	3 us	0110
Bipolar	+/- 1.25V	4	3 us	0111
Unipolar	0V ~ 10V	1	3 us	1000
Unipolar	0V ~ 5V	2	3 us	1001
Unipolar	0V ~ 2.5V	4	3 us	1010
Unipolar	0V ~ 1.25V	8	3 us	1011

The configuration table of PCI-1202H/1800H/1802H is given as follows:

Bipolar/Unipolar	Input Signal Range	Gain	Settling Time	[B9,B8,B7,B6]
Bipolar	+/- 5V	1	23 us	0000
Bipolar	+/- 0.5V	10	28 us	0001
Bipolar	+/- 0.05V	100	140 us	0010
Bipolar	+/- 0.005V	1000	1300 us	0011
Bipolar	+/- 10V	0.5	23 us	0100
Bipolar	+/- 1V	5	28 us	0101
Bipolar	+/- 0.1V	50	140 us	0110
Bipolar	+/- 0.01V	500	1300 us	0111
Unipolar	0V ~ 10V	1	23 us	1000
Unipolar	0V ~ 1V	10	28 us	1001
Unipolar	0V ~ 0.1V	100	140 us	1010
Unipolar	0V ~ 0.01V	1000	1300 us	1011

### 3.6.1.5 Set Channel Configuration

The demo program to set the channel/gain is given as follows:

```
WORD P180X_SetChannelConfig(WORD wAdChannel, WORD wAdConfig)
{
WORD wConfig,wChannel;

wChannel = (wAdChannel&0x1f);
wSysConfig = (wAdConfig&0x1f); // store for P1802_AdPolling
wConfig = (wAdConfig&0x0f);
wConfig = wConfig << 6;
wConfig += wChannel;

/* Bit15=1 --> no reset FIFO
  Bit14=?
  Bit13=?
  Bit12=0 --> command [001] --> set channel&Config command
  Bit11=0
  Bit10=1
  Bit9 =B --> Range control code [BB] --> unipolar/bipolar & divided by 2
  Bit8 =B
  Bit7 =B --> gain control code [BB] --> 1/10/100/1000 or 1/2/4/8
  Bit6 =B
  Bit5 =?
  Bit4-Bit0 --> channel number */
wConfig+= 0x8400; // this is set channel config command
return(pic_control(wConfig));
}
```

- **P1202\_SetChannelConfig(...)** is designed for PCI-1202H/L
- **P1602\_SetChannelConfig(...)** is designed for PCI-1602 and PCI-1602F

### 3.6.1.6 Calculate the A/D Value

**The demo program to calculate the real A/D value is given as follows:**

```
double ComputeRealValue(DWORD dwAdConfig, DWORD dwAdHex)
```

```
{
```

```
WORD wZERO;
```

```
double dfMAX, dfVal;
```

```
switch (dwAdConfig)
```

```
{
  case 0 : wZERO=2048; dfMAX=5.0;   break;
  case 1 : wZERO=2048; dfMAX=2.5;   break;
  case 2 : wZERO=2048; dfMAX=1.25;  break;
  case 3 : wZERO=2048; dfMAX=0.625; break;
  case 4 : wZERO=2048; dfMAX=10.0;  break;
  case 5 : wZERO=2048; dfMAX=5.0;   break;
  case 6 : wZERO=2048; dfMAX=2.5;   break;
  case 7 : wZERO=2048; dfMAX=1.25;  break ;
  case 8 : wZERO= 0; dfMAX=10.0/2.0; break;
  case 9 : wZERO= 0; dfMAX=5.0/2.0; break;
  case 10: wZERO= 0; dfMAX=2.5/2.0; break;
  case 11: wZERO= 0; dfMAX=1.25/2.0; break;
```

For PCI-1202/1800/1802L

Note: B4=0 is used to identify PGL

```

  case 0x10 : wZERO=2048; dfMAX=5.0;   break;
  case 0x11 : wZERO=2048; dfMAX=0.5;   break;
  case 0x12 : wZERO=2048; dfMAX=0.05;  break;
  case 0x13 : wZERO=2048; dfMAX=0.005; break;
  case 0x14 : wZERO=2048; dfMAX=10.0;  break;
  case 0x15 : wZERO=2048; dfMAX=1.0;   break ;
  case 0x16 : wZERO=2048; dfMAX=0.1;   break;
  case 0x17 : wZERO=2048; dfMAX=0.01;  break;
  case 0x18 : wZERO= 0; dfMAX=10.0/2.0; break ;
  case 0x19 : wZERO= 0; dfMAX=1.0/2.0; break;
  case 0x1A : wZERO= 0; dfMAX=0.1/2.0; break;
  case 0x1B : wZERO= 0; dfMAX=0.01/2.0; break;
```

For PCI-1202/1800/1802H

Note: B4=1 is used to identify PGH

```
default: return(ConfigCodeError); }
```

```
dfVal=(((double)(wAdHex)-wZERO)/2048.0)*dfMAX;
```

```
return(dfVal);
```

```
}
```



### 3.6.1.7 Command Sets of MagicScan Controller

The command sets of MagicScan controller are given as follows:

Command	[B12~B10]	Descriptions
Reset	[0 0 0]	Reset the MagicScan controller. <b>The software driver must send this command once after power-on.</b>
Set channel/gain	[0 0 1]	Set the channel/gain value of the <b>fixed-channel mode</b> . It will not affect the scan queue.
Add to scan queue	[1 0 0]	Add the channel/gain code to the scan queue. (At most 48 scan-channels can be stored in the MagicScan controller.)
Start MagicScan	[1 0 1]	Start the MagicScan controller
Stop MagicScan	[0 1 0]	Stop the MagicScan controller.
Get ODM number	[1 1 0]	Get the ODM number of the PCI-1202/1602/1800/1802.

**The demo program to reset the MagicScan controller is given as follows:**

```
wVal=pic_control(0xC000);          /* 11?0 00?? ???? ???? cmd_000=reset */
```

**The demo program to clear MagicScan queue is given as follows:**

```
WORD P180X_ClearScan(void)
{
WORD i;
for(i=0; i<32; i++) wMagicScanSave[i]=0;
disable_timer0();
disable_timer1();
return(pic_control(0xC000));      /* 11?0 00?? ???? ???? cmd_000=reset */
}
```

- **P1202\_ClearScan(...)** is designed for PCI-1202H/L
- **P1602\_ClearScan(...)** is designed for PCI-1602 and PCI-1602F

**The demo program of send command to MagicScan control is given as follows:**

```
WORD pic_control(WORD i)
{
WORD j;

if ((inport(wAddrCtrl)&0x04)==0)
{
    outport(wAddrCtrl,0xffff);          /* send a recovery to PIC */
}

j=0;
while ((inport(wAddrCtrl)&0x04)==0)
{
    j++;
    if (j>65530) return(AdControllerError); /* time out */
}

i = i & 0xDFFF;                        /* set pic low !! */
outport(wAddrCtrl,i);

j=0;
while ((inport(wAddrCtrl)&0x04)!=0)
{
    j++;
    if (j>65530) return(AdControllerError); /* time out */
}

outport(wAddrCtrl,(WORD)(i | 0x2000)); /* set pic high !! */
j=0;
while ((inport(wAddrCtrl)&0x04)==0)
{
    j++;
    if (j>65530) return(AdControllerError); /* time out */
}
return(NoError);
}
```

**The demo program to set the channel/gain is given as follows:**

```
WORD P180X_SetChannelConfig(WORD wAdChannel, WORD wAdConfig)
{
WORD wConfig,wChannel;

wChannel = (wAdChannel&0x1f);
wSysConfig = (wAdConfig&0x1f); // store for P1802_AdPolling
wConfig = (wAdConfig&0x0f);
wConfig = wConfig << 6;
wConfig += wChannel;

/* Bit15=1 --> no reset FIFO
  Bit14=?
  Bit13=?
  Bit12=0 --> command [001] --> set channel&Config command
  Bit11=0
  Bit10=1
  Bit9 =B --> Range control code [BB] --> unipolar/bipolar & divided by 2
  Bit8 =B
  Bit7 =B --> gain control code [BB] --> 1/10/100/1000 or 1/2/4/8
  Bit6 =B
  Bit5 =?
  Bit4-Bit0 --> channel number */
wConfig+= 0x8400; // this is set channel config command
return(pic_control(wConfig));
}
```

- **P1202\_SetChannelConfig(...)** is designed for PCI-1202H/L
- **P1602\_SetChannelConfig(...)** is designed for PCI-1602 and PCI-1602F

**The demo program to add to MagicScan queue is given as follows:**

```
WORD P180X_AddToScan(WORD wAdChannel, WORD wAdConfig, WORD
wAverage, WORD wLowAlarm, WORD wHighAlarm, WORD wAlarmType)
{WORD wConfig,wChannel,wRetVal;
```

```
if (wAlarmType>=5) return(AlarmTypeError);
wMagicLowAlarm[wMP]=wLowAlarm;
wMagicHighAlarm[wMP]=wHighAlarm;
wMagicAlarmType[wMP]=wAlarmType;
wChannel = wAdChannel&0x1f;
wMagicChannel[wMP]=wChannel;
wSysConfig = wAdConfig&0x1f; /* Store for P180X_AdPolling */
wMagicConfig[wMP]=wSysConfig;
wMagicAve[wMP]=wAverage;
wConfig = wAdConfig&0x0f;
wConfig = wConfig << 6;
wConfig += wChannel;

/* Bit15=1 --> no reset FIFO
  Bit14=1
  Bit13=?
  Bit12=1 --> command [100] --> add_to_scan command
  Bit11=0
  Bit10=0
  Bit9 =B --> Range control code [BB] --> unipolar/bipolar & divided by 2
  Bit8 =B
  Bit7 =B --> gain control code [BB] --> 1/10/100/1000 or 1/2/4/8
  Bit6 =B
  Bit5 =?
  Bit4-Bit0 --> channel number */
wConfig+= 0xD000; /* this is add_to_scan_queue command */
wRetVal=pic_control(wConfig);
if (wRetVal!=0) return(wRetVal);
return(NoError);
}
```

- **P1202\_AddToScan(...)** is designed for PCI-1202H/L
- **P1602\_AddToScan(...)** is designed for PCI-1602 and PCI-1602F

**The demo program to start MagicScan operation is given as follows:**

```
WORD P180X_StartScan(WORD wSampleRate, WORD wNum)
{
WORD wVal;
WORD wRetVal;

wMagicNum=wNum;
disable_timer0();          /* Disable pacer timer first */
                           /* start MagicScan controller */
wRetVal=pic_control(0xD400); /* 11?1 01?? ???? ???? cmd_101=start scan */
if (wRetVal!=0) return(wVal);

                           /* Clear FIFO to clear all data */
outport(wAddrCtrl,0x2000); /* Bit15=0=clear FIFO, Bit13=1=not PIC cmd */
outport(wAddrCtrl,0xA000); /* Bit15=1=no reset FIFO, BIT13=1=not PIC cmd */

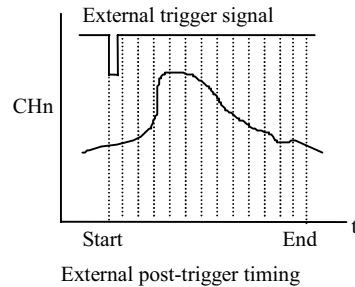
enable_timer0(wSampleRate); /* Enable pacer timer, sampling rate=8M/dwSample */
magic_scan();               /* Call MagicScan subroutine(DOS) or thread(Windows) */
return(NoError);
}
```

- **P1202\_StartScan(...)** is designed for PCI-1202H/L
- **P1602\_StartScan(...)** is designed for PCI-1602 and PCI-1602F

### 3.6.1.8 External Trigger Control

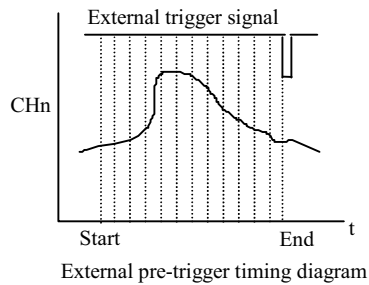
The operation steps of **post-trigger** are given as follows:

- Step 1: Disable all external trigger
- Step 2: Set the pacer rate of timer-1
- Step 3: Clear FIFO & disable timer-1
- Step4: Wait until external trigger signal to enable timer-1
- Step 5: Fetch N data(N=End-Start)
- Step 6: Stop all timer



The operation steps of **pre-trigger** are given as follows:

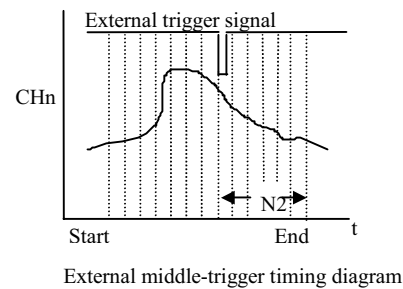
- Step 1: Disable all external trigger
- Step 2: Set the pacer rate of timer-1
- Step 3: Clear FIFO & enable timer-1
- Step 4: Circular-fetch N-data until external trigger signal to disable timer-1 (N=End-Start)
- Step 5: Stop all timer



NOTE: The circular-fetch operation is performed by software

The operation steps of **middle-trigger** are given as follows:

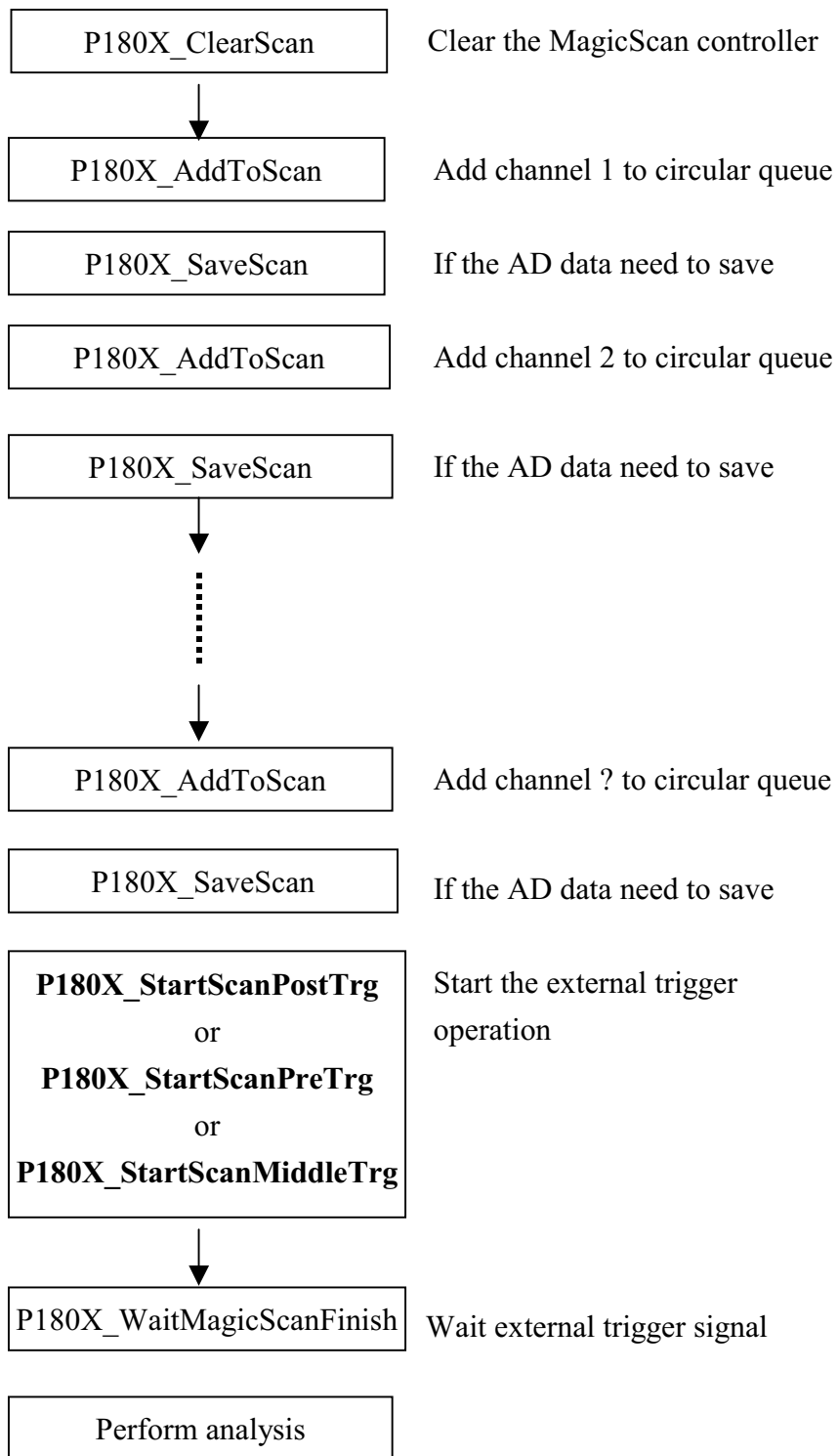
- Step 1: Disable all external trigger
- Step 2: Set the pacer rate of timer-1
- Step 3: Clear FIFO & enable timer-1
- Step4: Circular-fetch N-data until external trigger signal (N=End-Start)
- Step 5: Fetch more N2-data & stop timer-1
- Step 6: Stop all timer



NOTE: The circular-fetch operation is performed by software

- **Note 1: The external trigger operation must use with the MagicScan controller. The software flowchart of external trigger is given in next page.**
- **Note 2: The post-trigger operation can use all MagicScan function.**
- **Note 3: The user can't enable MagicScan HI/LO alarm and digital filter function in the pre-trigger & middle-trigger operation.**

The software flowchart of external trigger operation is given as follows:



- Refer to chapter-4 for more information
- This flowchart is validate for PCI-1202/1602/1800/1802

The demo program of post-trigger is given as follows:

```
wRetVal=P180X_ClearScan();
wRetVal += P180X_AddToScan(0,0,1,0,0,0); // CH:0 to scan
wRetVal += P180X_SaveScan(0,wV0);
wRetVal += P180X_AddToScan(2,0,1,0,0,0); // CH:2 to scan
wRetVal += P180X_SaveScan(1,wV2); // Notice: 1 not 2
// ^ : This is a ordinal number in
// Scan Queue not a channel number.
wRetVal += P180X_StartScanPostTrg(wSampleRateDiv,DATALENGTH,nPriority);
```

```
if (wRetVal==0) sprintf(cShow,"2. External Post-Trigger Setup OK");
else sprintf(cShow,"2. External Post-Trigger Setup Error");
TextOut(hdc,x*dx,(y+iLine)*dy,cShow,strlen(cShow)); iLine++;
```

```
for (; )
{
P180X_ReadScanStatus(&wStatus,&dwLowAlarm,&dwHighAlarm);
if (wStatus>1) break;
Sleep(10);
}
```

```
sprintf(cShow,"3. ScanStatus=%x",wStatus);
TextOut(hdc,x*dx,(y+iLine)*dy,cShow,strlen(cShow)); iLine++;
```

```
wRetVal=P180X_StopMagicScan();
```

```
if (wRetVal!=NoError)
{
sprintf(cShow,"4. StopMagicScan Error");
TextOut(hdc,x*dx,(y+iLine)*dy,cShow,strlen(cShow)); iLine++;
for (dwI=0; dwI<100; dwI++) Beep(10,10);
}
```

```
SHOW_WAVE(hwnd,LINE1,wV0,1);
```

```
SHOW_WAVE(hwnd,LINE2,wV2,1);
```

- Refer to **DEMO23.C** for completely source program



The B13 must set to 1 to set the external trigger logic. The external trigger controller commands are given as follows:

Trigger	Command sequences [B12, B11, B10 ]	Descriptions
Disable external trigger (for PCI-1800/1X02)	[ 1, 0, X ]	Disable all external trigger.
<b>Post-trigger</b> (for PCI-1202/1602/ 1800/1802)	[ 1, 0, X ] [ 1, 0, X ] [ 1, 1, 1 ] [ 1, 0, X ]	(1) disable all external trigger (2) set pacer time-1 (3) clear FIFO and disable timer-1 (4) waiting for external signal to enable timer-1 (5) fetch N data (6) stop all timer & disable all external trigger
<b>Pre-trigger</b> (for PCI-1202/1602 & PCI-1800/1802/ver-F)	[ 1, 0, X ] [ 0, 1, X ] [ 1, 1, 0 ] [ 1, 0, X ]	(1) disable all external trigger (2) set pacer timer-1 (3) clear FIFO and enable timer-1 (4) waiting for the external signal to stop timer-1. (5) circular-fetch the last N data (6) stop all timer & disable all trigger
<b>Middle-trigger</b> (for PCI-1202/1602 & PCI-1800/1802/ver-F)	[ 1, 0, X ] [ 0, 1, X ] [ 1, 1, 1 ] [ 1, 0, X ]	(1) disable all external trigger (2) set pacer timer-1 (3) clear FIFO and enable timer-1 (4) waiting for the external signal. (5) fetch more N2 data (circular-fetch) (6) stop all timer & disable all trigger
Pre-trigger (for PCI-1800/1802) <b>(version-C)</b>	[ 1, 0, X ] [ 0, 1, X ] [ 1, 1, 1 ] [ 1, 0, X ]	(1) disable all external trigger (2) set pacer timer-1 (3) clear FIFO and enable timer-1 (4) waiting for the external signal to stop timer-1. (5) keep the last N data (circular-fetch) (6) stop all timer & disable all trigger
Middle-trigger (for PCI-1800/1802) <b>(version-C)</b>	[ 1, 0, X ] [ 0, 1, X ] [ 1, 1, 0 ] [ 0, 1, X ] [ 1, 0, X ]	(1) disable all external trigger (2) set pacer timer-1 (3) clear FIFO and enable timer-1 (4) waiting for the external signal to stop timer-1 (5) enable timer-1 (6) fetch more N2 data (7) stop all timer & disable all trigger

---

**The Windows driver of post-trigger is given as follows:**

```
WORD CALLBACK P180X_StartScanPostTrg(WORD wSampleRateDiv, DWORD dwNum,
SHORT nPriority)
```

```
{
disable_timer0(); // disable internal pacer timer
disable_timer1(); // disable external pacer timer
```

```
wVal=pic_control(0xD400); /* 11?1 01?? ??? ???? cmd_101=start scan */
if (wVal!=0) return(wVal);
```

```
_outpw(wAddrCtrl,0xf000); // 1. disable all external trigger
enable_timer1(wSampleRateDiv); // 2. Sampling rate=8M/dwSampleRateDiv
_outpw(wAddrCtrl,0x7000); // 3. B15=0,S2=1,S1=S0=0 --> clr FIFO
_outpw(wAddrCtrl,0xf000); // 3. B15=1,S2=1,S1=S0=0 --> disable timer-1
_outpw(wAddrCtrl,0xfc00); // 4. S2=1, S1=1, S0=1 --> wait ext signal to
// enable timer-1
```

```
// create magicscan thread
InitializeCriticalSection(&MagicScan_CS);
wThreadStatus=0; wAskThreadStop=0;
hThread=CreateThread(NULL,0,(LPTHREAD_START_ROUTINE)magic_scan,
NULL, 0,&dwThreadID);// can use all MagicScan functions
SetThreadPriority(hThread,nPriority);
i=0;
for(;;)
{
EnterCriticalSection(&MagicScan_CS);
j=wThreadStatus;
LeaveCriticalSection(&MagicScan_CS);
if (j!=0) break;
i++; Sleep(1);
if (i>1000) return(ThreadCreateError);
}
return(NoError);
}
```

- P1202\_StartScanPostTrg(...) is designed for PCI-1202H/L
- P1602\_StartScanPostTrg(...) is designed for PCI-1602 and PCI-1602F

**The windows driver of pre-trigger is given as follows:**

```
WORD CALLBACK P180X_StartScanPreTrg(WORD wSampleRateDiv, DWORD dwNum,
SHORT nPriority)
```

```
{
disable_timer0(); // disable internal pacer timer
disable_timer1(); // disable external pacer timer

wVal=pic_control(0xD400); /* 11?1 01?? ???? ???? cmd_101=start scan */
if (wVal!=0) return(wVal);
```

```
_outpw(wAddrCtrl,0xf000); // 1. disable all external trigger
enable_timer1(wSampleRateDiv); // 2. Sampling rate=8M/dwSampleRateDiv
_outpw(wAddrCtrl,0x6800); // 3. B15=0,S2=0,S1=1,S0=0 --> clr FIFO
_outpw(wAddrCtrl,0xE800); // 3. B15=1,S2=0,S1=1,S0=0 --> enable timer-1
_outpw(wAddrCtrl,0xF800); // 4. S2=1; S1=1; S0=0 --> wait ext signal to
// disable timer-1
```

```
// create magicscan thread
InitializeCriticalSection(&MagicScan_CS);
wThreadStatus=0; wPreMid=0; wAskThreadStop=0; // pre-trigger
hThread=CreateThread(NULL,0,(LPTHREAD_START_ROUTINE)
magic_scan_pre_mid_trg, NULL, 0,&dwThreadID);
SetThreadPriority(hThread,nPriority); // can not use HI/LO alarm & digital filter
i=0;
for(;;)
{
EnterCriticalSection(&MagicScan_CS);
j=wThreadStatus;
LeaveCriticalSection(&MagicScan_CS);
if (j!=0) break;
i++; Sleep(1);
if (i>1000) return(ThreadCreateError);
}
return(NoError);
}
```

- **P1202\_StartScanPostTrg(...)** is designed for PCI-1202H/L
- **P1602\_StartScanPostTrg(...)** is designed for PCI-1602 and PCI-1602F

**The windows driver of middle-trigger is given as follows:**

```
WORD CALLBACK P180X_StartScanMiddleTrg(WORD wSampleRateDiv, DWORD  
dwNum, SHORT nPriority)
```

```
{  
disable_timer0(); // disable internal pacer timer  
disable_timer1(); // disable external pacer timer
```

```
wVal=pic_control(0xD400); /* 11?1 01?? ???? ???? cmd_101=start scan */  
if (wVal!=0) return(wVal);
```

```
_outpw(wAddrCtrl,0xf000); // 1. disable all external trigger  
enable_timer1(wSampleRateDiv); // 2. Sampling rate=8M/dwSampleRateDiv  
_outpw(wAddrCtrl,0x6800); // 3. B15=0,S2=0,S1=1,S0=0 --> clr FIFO  
_outpw(wAddrCtrl,0xE800); // 3. B15=1,S2=0,S1=1,S0=0 --> enable timer-1  
_outpw(wAddrCtrl,0xFC00); // 4. S2=1; S1=1; S0=1 --> wait ext signal
```

```
// create magicscan thread  
InitializeCriticalSection(&MagicScan_CS);  
wThreadStatus=0; wPreMid=1; wAskThreadStop=0; // middle-trigger  
hThread=CreateThread(NULL,0,(LPTHREAD_START_ROUTINE,  
magic_scan_pre_mid_trg, NULL, 0,&dwThreadID);  
SetThreadPriority(hThread,nPriority); // can not use HI/LO alarm & digital filter
```

```
i=0;  
for(;;)  
{  
EnterCriticalSection(&MagicScan_CS);  
j=wThreadStatus;  
LeaveCriticalSection(&MagicScan_CS);  
if (j!=0) break;  
i++; Sleep(1);  
if (i>1000) return(ThreadCreateError);  
}  
return(NoError);  
}
```

- **P1202\_StartScanPostTrg(...)** is designed for PCI-1202H/L
- **P1602\_StartScanPostTrg(...)** is designed for PCI-1602 and PCI-1602F

**The pre-trigger driver for PCI-1800/1802/ver-C is given as follows:**

```
WORD CALLBACK P180X_StartScanPreTrgVerC(WORD wSampleRateDiv, DWORD
dwNum, SHORT nPriority)
{
disable_timer0(); // disable internal pacer timer
disable_timer1(); // disable external pacer timer

wVal=pic_control(0xD400); /* 11?1 01?? ???? ???? cmd_101=start scan */
if (wVal!=0) return(wVal);
```

```
_outpw(wAddrCtrl,0xf000); // 1. disable all external trigger
enable_timer1(wSampleRateDiv); // 2. Sampling rate=8M/dwSampleRateDiv
_outpw(wAddrCtrl,0x6800); // 3. B15=0,S2=0,S1=1,S0=0 --> clr FIFO
_outpw(wAddrCtrl,0xE800); // 3. B15=1,S2=0,S1=1,S0=0 --> enable timer-1
_outpw(wAddrCtrl,0xF800); // 4. S2=1; S1=1; S0=0 --> wait ext signal to
// disable timer-1
```

```
// create magicscan thread
InitializeCriticalSection(&MagicScan_CS);
wThreadStatus=0; wPreMid=0; wAskThreadStop=0; // pre-trigger
hThread=CreateThread(NULL,0,(LPTHREAD_START_ROUTINE,
magic_scan_pre_mid_trg_ver_c, NULL, 0,&dwThreadID);
SetThreadPriority(hThread,nPriority);
i=0;
for(;;)
{
EnterCriticalSection(&MagicScan_CS);
j=wThreadStatus;
LeaveCriticalSection(&MagicScan_CS);
if (j!=0) break;
i++; Sleep(1);
if (i>1000) return(ThreadCreateError);
}
return(NoError);
}
```

- **This driver is designed for PCI-1800/1802 version-C**

**The middle-trigger driver for PCI-1800/1802/ver-C is given as follows:**

```
WORD CALLBACK P180X_StartScanMiddleTrgVerC(WORD wSampleRateDiv, DWORD
dwNum, SHORT nPriority)
```

```
{
disable_timer0(); // disable internal pacer timer
disable_timer1(); // disable external pacer timer
```

```
wVal=pic_control(0xD400); /* 11?1 01?? ???? ???? cmd_101=start scan */
if (wVal!=0) return(wVal);
```

<pre>_outpw(wAddrCtrl,0xf000); // 1. disable all external trigger</pre>
<pre>enable_timer1(wSampleRateDiv); // 2. Sampling rate=8M/dwSampleRateDiv</pre>
<pre>_outpw(wAddrCtrl,0x6800); // 3. B15=0,S2=0,S1=1,S0=0 --&gt; clr FIFO</pre>
<pre>_outpw(wAddrCtrl,0xE800); // 3. B15=1,S2=0,S1=1,S0=0 --&gt; enable timer-1</pre>
<pre>_outpw(wAddrCtrl,0xF800); // 4. S2=1; S1=1; S0=0 --&gt; wait ext signal to</pre>
<pre>// disable timer-1</pre>

```
// create magicscan thread
```

```
InitializeCriticalSection(&MagicScan_CS);
```

```
wThreadStatus=0; wPreMid=1; wAskThreadStop=0; // middle-trigger
```

```
hThread=CreateThread(NULL,0,(LPTHREAD_START_ROUTINE,
```

```
magic_scan_pre_mid_trg_ver_c, NULL, 0,&dwThreadID);
```

```
SetThreadPriority(hThread,nPriority);
```

```
i=0;
```

```
for(;;)
```

```
{
```

```
EnterCriticalSection(&MagicScan_CS);
```

```
j=wThreadStatus;
```

```
LeaveCriticalSection(&MagicScan_CS);
```

```
if (j!=0) break;
```

```
i++; Sleep(1);
```

```
if (i>1000) return(ThreadCreateError);
```

```
}
```

```
return(NoError);
```

```
}
```

- This driver is designed for PCI-1800/1802 version-C

The external trigger drivers are given as follows:

Driver Name	demo program	Applications
P180X_StartScanPostTrg(...)	demo23.c	for PCI-1800/1802 ver-C & ver-F
P180X_StartScanPreTrg(...)	demo24.c	for PCI-1800/1802 ver-F
P180X_StartScanMiddleTrg(...)	demo25.c	for PCI-1800/1802 ver-F
P180X_StartScanPreTrgOld(...)	demo26.c	for PCI-1800/1802 ver-C
P180X_StartScanMiddleTrgOld(...)	demo27.c	for PCI-1800/1802 ver-C
P1202_StartScanPostTrg(...)	demo23.c	for PCI-1202
P1202_StartScanPreTrg(...)	demo24.c	for PCI-1202
P1202_StartScanMiddleTrg(...)	demo25.c	for PCI-1202
P1602_StartScanPostTrg(...)	demo23.c	for PCI-1602
P1602_StartScanPreTrg(...)	demo24.c	for PCI-1602
P1602_StartScanMiddleTrg(...)	demo25.c	for PCI-1602

### 3.6.1.9 Clear FIFO Bit

The B15 is used to reset the on-board FIFO. When set to low, FIFO will be clear. The FIFO must be clear once after power-on.

**The demo program of handshaking is given as follows:**

```
// Clear FIFO to clear all data
outport(wAddrCtrl,0x2000); /* Bit15=0=clear FIFO, Bit13=1=not PIC cmd */
outport(wAddrCtrl,0xA000); /* Bit15=1=no reset FIFO, BIT13=1=not PIC cmd */
```

### 3.6.1.10 Handshake Control Bit

Set the B13 to 0 if the command is sent to the MagicScan controller. Keep this bit at high when not used.

**The demo program of handshaking is given as follows:**

```
WORD pic_control(WORD i)
{
WORD j;

if ((inport(wAddrCtrl)&0x04)==0)
{
outport(wAddrCtrl,0xffff);          /* send a recovery to PIC */
}
j=0;
while ((inport(wAddrCtrl)&0x04)==0)
{
j++;
if (j>65530) return(AdControllerError); /* time out */
}
i = i & 0xDFFF;                      /* set pic low !! */
outport(wAddrCtrl,i);
j=0;
while ((inport(wAddrCtrl)&0x04)!=0)
{
j++;
if (j>65530) return(AdControllerError); /* time out */
}
outport(wAddrCtrl,(WORD)(i | 0x2000)); /* set pic high !! */
j=0;
while ((inport(wAddrCtrl)&0x04)==0)
{
j++;
if (j>65530) return(AdControllerError); //time out
}
return(NoError);
}
```





### 3.6.3 The A/D software trigger register

Writing to this port will perform a software trigger A/D conversion. Although the PC can send very fast trigger signal (more than 333K ), the max. sampling rate of A/D conversion can not over 330K samples/second. The timing diagram is given as follows:

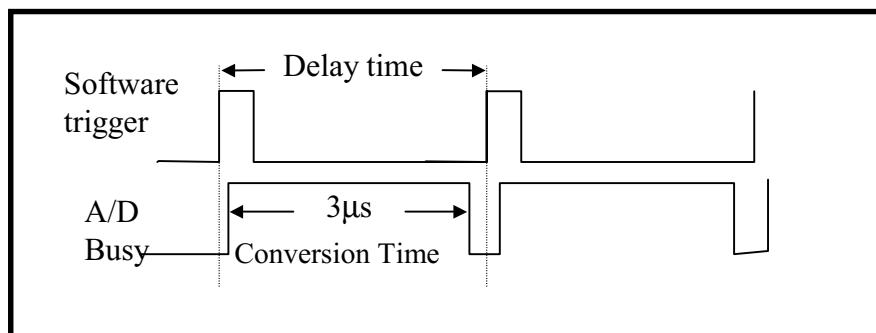


Figure 3-3: Trigger delay time.

**The demo program of software trigger A/D conversion is given as follows:**

```
WORD P180X_AdPollingHex(Word *AdVal)
{
WORD wVal, wTime;
//Clear FIFO
outport(wAddrCtrl,0x2000); //B15=0=clear FIFO, B13=1=not MagicScan controller cmd
outport(wAddrCtrl,0xA000); //B15=1=no clear FIFO, B13=1= not MagicScan controller cmd
outport((WORD)(wAddrCtrl+4),0xffff); /* generate a software trigger pulse */
wTime=0;
for (;;)
{
wVal=inport(wAddrCtrl)&0x20; // wait for ready signal
if (wVal!=0) break; /* If B4==1 → A/D data ready */
wTime++;
if (wTime>32760) return(AdPollingTimeOut);
}
AdVal=inport(wAddrAdda)&0x0fff; /* Read the available A/D data from FIFO */
return(NoError); /* 0xffff for PCI-1602/1602F */
}
```

- **P1202\_AdPollingHex(...)** is designed for PCI-1202H/L
- **P1602\_AdPollingHex(...)** is designed for PCI-1602 and PCI-1602F

## 3.7 Section 4: D/I/O Register

- I/O address of D/I = wAddrDio
- I/O address of D/O = wAddrDio

The PCI-1800/1802 provide 16-channel digital input and 16-channel digital output. All levels are TTL compatible. The connections diagram and block diagram are given below :

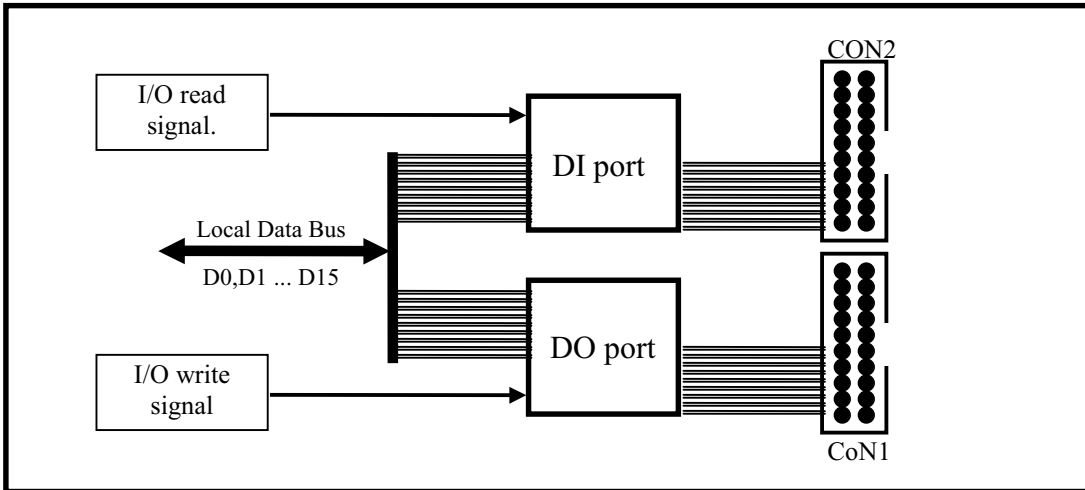


Figure 3-4: DIO block diagram.

The D/I port can be connected to the DB-16P. The DB-16P is a 16-channel isolated digital input daughter board. The D/O port can be connected to the DB-16R or DB-24PR. The DB-16R is a 16-channel relay output board. The DB-24R is a 24-channel power relay output board.

**The demo program of D/I/O is given as follows:**

```
WORD P180X_Di(WORD *wDi)
{
*wDi=inport(wAddrDio)&0xffff;
return(NoError);
}
```

- P1202\_Di(...) for PCI-1202
- P1602\_Di(...) for PCI-1602

```
WORD P180X_Do(WORD wDo)
{
outport(wAddrDio,wDo);
return(NoError);
}
```

- P1202\_Do(...) for PCI-1202
- P1602\_Do(...) for PCI-1602

## 3.8 Section 5: A/D & D/A Register

- I/O address of DA-0 = wAddrAdda
- I/O address of DA-1 = wAddrAdda + 1\*4
- I/O address of FIFO = wAddrAdda

Writing data to this section will write data to the DACs and reading data from this port will read the data from A/D FIFO. The read/write operation is given as follows:

Port	Read	Write
Section + 0	A/D FIFO.	DAC1 write.
Section + 4	Reserved	DAC2 write.

The PCI-1800/1802 provide 2 independent 12-bits D/A converters with double buffer, bipolar voltage output. The output voltage can be  $\pm 5V$  or  $\pm 10V$  selected by J1. When the PCI-1800/1802 is first power-on, the D/A will be in the floating state. The D/A will go to the programmed state after executing D/A output command. The block diagram is given as below:

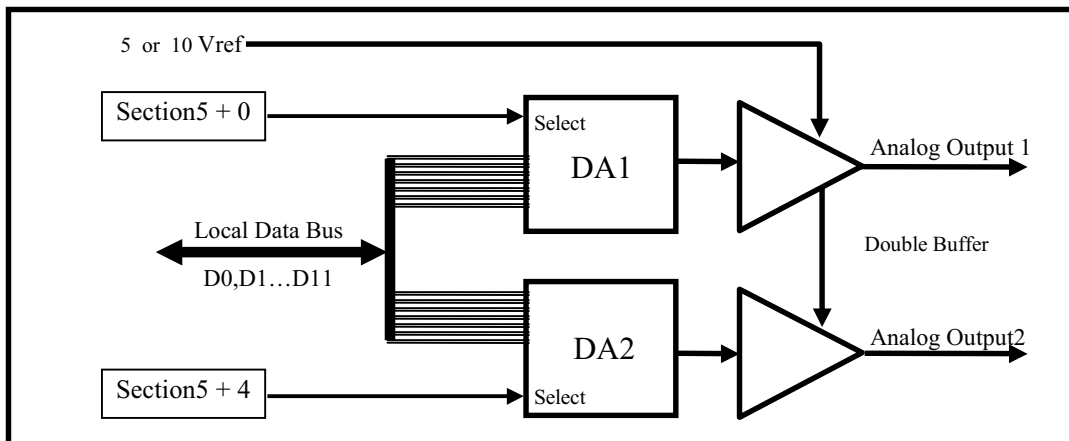


Figure 4-2 : D/A output diagram.

Note: The D/A output is **floating after first power-on**. The D/A output will be enabled after executing D/A output command. This is the common feature of PCI-1202/1602/1800/1802.

**The demo program for D/A is given as follows:**

WORD P180X\_Da(WORD wDaChannel, WORD wDaVal)

```
{
if (wDaChannel==0) /* channel 0 */
{
outport(wAddrAdda,wDaVal);
return(NoError);
}
else if (wDaChannel==1) /* channel_1 */
{
outport((wAddrAdda+4),wDaVal);
return(NoError);
}
else return(DaChannelError);
}
```

- |  |
|--|
| <ul style="list-style-type: none"> <li>● P1202_Da(...) for PCI-1202</li> <li>● P1602_Da(...) for PCI-1602</li> </ul> |
|--|

**The demo program of software trigger A/D conversion is given as follows:**

WORD P180X\_AdPollingHex(Word \*AdVal)

```
{
WORD wVal, wTime ;
```

- |  |
|--|
| <ul style="list-style-type: none"> <li>● P1202_AdPollingHex(...) for PCI-1202</li> <li>● P1602_AdPollingHex(...) for PCI-1602</li> </ul> |
|--|

```
//Clear FIFO
outport(wAddrCtrl,0x2000); // B15=0=clear FIFO, B13=1=not MagicScan controller cmd
outport(wAddrCtrl,0xA000); // B15=1=no clear FIFO, B13=1= not MagicScan controller cmd
outport((WORD)(wAddrCtrl+4),0xffff); /* generate a software trigger pulse */
```

```
wTime=0;
for (;;)
{
wVal=inport(wAddrCtrl)&0x20; // wait for ready signal
if (wVal!=0) break; /* if B4==1 → A/D data ready */
wTime++;
if (wTime>32760) return(AdPollingTimeOut);
}
```

```
AdVal=inport(wAddrAdda)&0x0fff; /* Read the available A/D data from FIFO */
return(NoError); /* 0x0fff for 12-bit ADC, 0xffff for 16-bit ADC */
}
```

## 4. A/D Conversion Operation

### 4.1 The Configuration Code Table

**PCI-1202L/1800L/1802L Configuration Code Table**

Bipolar/Unipolar	Input Signal Range	Gain	Settling Time	Configuration Code
Bipolar	+/- 5V	1	3 us	0x00
Bipolar	+/- 2.5V	2	3 us	0x01
Bipolar	+/- 1.25V	4	3 us	0x02
Bipolar	+/- 0.625V	8	3 us	0x03
Bipolar	+/- 10V	0.5	3 us	0x04
Bipolar	+/- 5V	1	3 us	0x05
Bipolar	+/- 2.5V	2	3 us	0x06
Bipolar	+/- 1.25V	4	3 us	0x07
Unipolar	0V ~ 10V	1	3 us	0x08
Unipolar	0V ~ 5V	2	3 us	0x09
Unipolar	0V ~ 2.5V	4	3 us	0x0A
Unipolar	0V ~ 1.25V	8	3 us	0x0B

**PCI-1602 Configuration Code Table**

Bipolar/Unipolar	Input Signal Range	Gain	Settling Time	Configuration Code
Bipolar	+/-10V	1	10 us	0
Bipolar	+/-5V	2	10 us	1
Bipolar	+/-2.5V	4	10 us	2
Bipolar	+/-1.25V	8	10 us	3

**PCI-1602F Configuration Code Table**

Bipolar/Unipolar	Input Signal Range	Gain	Settling Time	Configuration Code
Bipolar	+/-10V	1	5 us	0
Bipolar	+/-5V	2	5 us	1
Bipolar	+/-2.5V	4	5 us	2
Bipolar	+/-1.25V	8	5 us	3

**PCI-1202H/1800H/1802H Configuration Code Table**

Bipolar/Unipolar	Input Signal Range	Gain	Settling Time	Configuration Code
Bipolar	+/- 5V	1	23 us	0x10
Bipolar	+/- 0.5V	10	28 us	0x11
Bipolar	+/- 0.05V	100	140 us	0x12
Bipolar	+/- 0.005V	1000	1300 us	0x13
Bipolar	+/- 10V	0.5	23 us	0x14
Bipolar	+/- 1V	5	28 us	0x15
Bipolar	+/- 0.1V	50	140 us	0x16
Bipolar	+/- 0.01V	500	1300 us	0x17
Unipolar	0V ~ 10V	1	23 us	0x18
Unipolar	0V ~ 1V	10	28 us	0x19
Unipolar	0V ~ 0.1V	100	140 us	0x1A
Unipolar	0V ~ 0.01V	1000	1300 us	0x1B

## 4.2 The Unipolar/Bipolar

If the analog input signal is unipolar, you can measure this signal with bipolar setting (**this will reduce resolution**). If the analog input is bipolar, you must select bipolar configuration code to measure this signal.

## 4.3 The Input Signal Range

If the input range of analog signal is +/- 1V, you can measure this signal with +/-10V, +/-5V, +/-2.5V and +/- 1.25V configuration code setting. The only difference is the resolution. The resolution of +/- 2.5V is 4 times higher than in +/- 10V setting. **Select the correct configuration code will get the best resolution.**

## 4.4 The Settling Time

If the **channel number** or **gain factor** is changed, the hardware need **extra time for signal ready**. This is called the settling time. This limitation will apply both to the **Fixed-channel mode** and **MagicScan mode** AD conversions. So the user must take care to avoid the settling error. In the MagicScan mode, the MagicScan controller will control all details. The MagicScan controller will change the channel number and gain control just after every pacer trigger signal. **Therefore the limitation is “settling time  $\leq$  pacer timer” in MagicScan mode.**

---

## 4.5 How to Delay the Settling Time

In the software trigger mode, the software operation is given as follows:

1. send software trigger pulse
2. delay the settling time
3. read the A/D data

The **P180X\_DelayUs(...)** is a machine independent timer function. Therefore this function is suitable to delay the settling time. In the pacer trigger mode, the software does not have to call P180X\_DelayUs(...) The only limitation is that the pacer timer must be longer than the settling time. Refer to Sec. 4.1 for settling time details.



## 4.6 The AD Conversion Mode

The AD conversion operation of PCI-1202/1602/1800/1802 can be divided into two different mode: **Fixed-channel mode** and the **MagicScan mode**.

- The functions of fixed-channel mode are given as follows:

1. P180X\_SetChannelConfig
2. P180X\_AdPoling
3. P180X\_AdsPolling
4. P180X\_AdsPacer

The reading data is in double format

- The functions of MagicScan mode are given as follows:

1. P180X\_ClearScan
2. P180X\_StartScan
3. P180X\_ReadScanStatus
4. P180X\_AddToScan
5. P180X\_SaveScan
6. P180X\_WaitMagicScanFinish
7. **P180X\_StartScanPostTrg**
8. **P180X\_StartScanPreTrg**
9. **P180X\_StartScanMiddleTrg**

Data in 12 bits HEX format

7. For external trigger
8. For external trigger
9. For external trigger

- The functions of M\_ functions are given as follows:

1. P180X\_M\_FUN\_1
2. P180X\_M\_FUN\_2
3. P180X\_M\_FUN\_3
4. P180X\_M\_FUN\_4

- The functions of continuous capture with storing data to main memory are given as follows: (two board operating simultaneously)

1. P180X\_FunA\_Start
2. P180X\_FunA\_ReadStatus
3. P180X\_FunA\_Stop
4. P180X\_FunA\_Get

- The functions of continuous capture with storing data to main memory are given as follows: (single board operating)

1. P180X\_FunB\_Start
2. P180X\_FunB\_ReadStatus
3. P180X\_FunB\_Stop
4. P180X\_FunB\_Get

- The functions of continuous capture are given as follows:

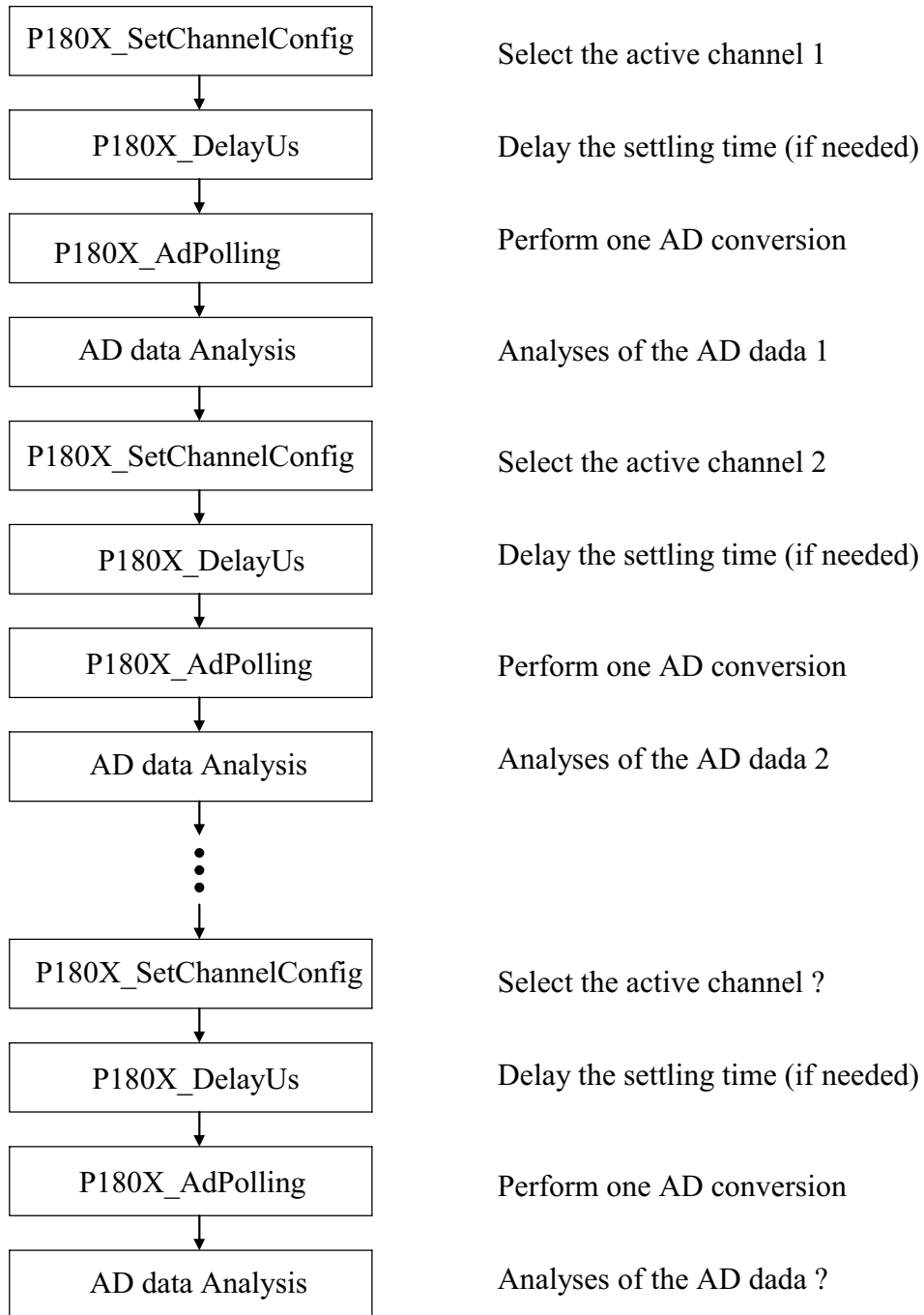
1. P180X\_Card0\_StartScan
2. P180X\_Card0\_ReadStatus
3. P180X\_Card0\_StopScan
4. P180X\_Card1\_StartScan
5. P180X\_Card1\_ReadStatus
6. P180X\_Card1\_StopScan

Group-0: for card\_0 continuous capture function

Group-1: for card\_1 continuous capture function

## 4.7 The Fixed-channel Mode AD Conversion

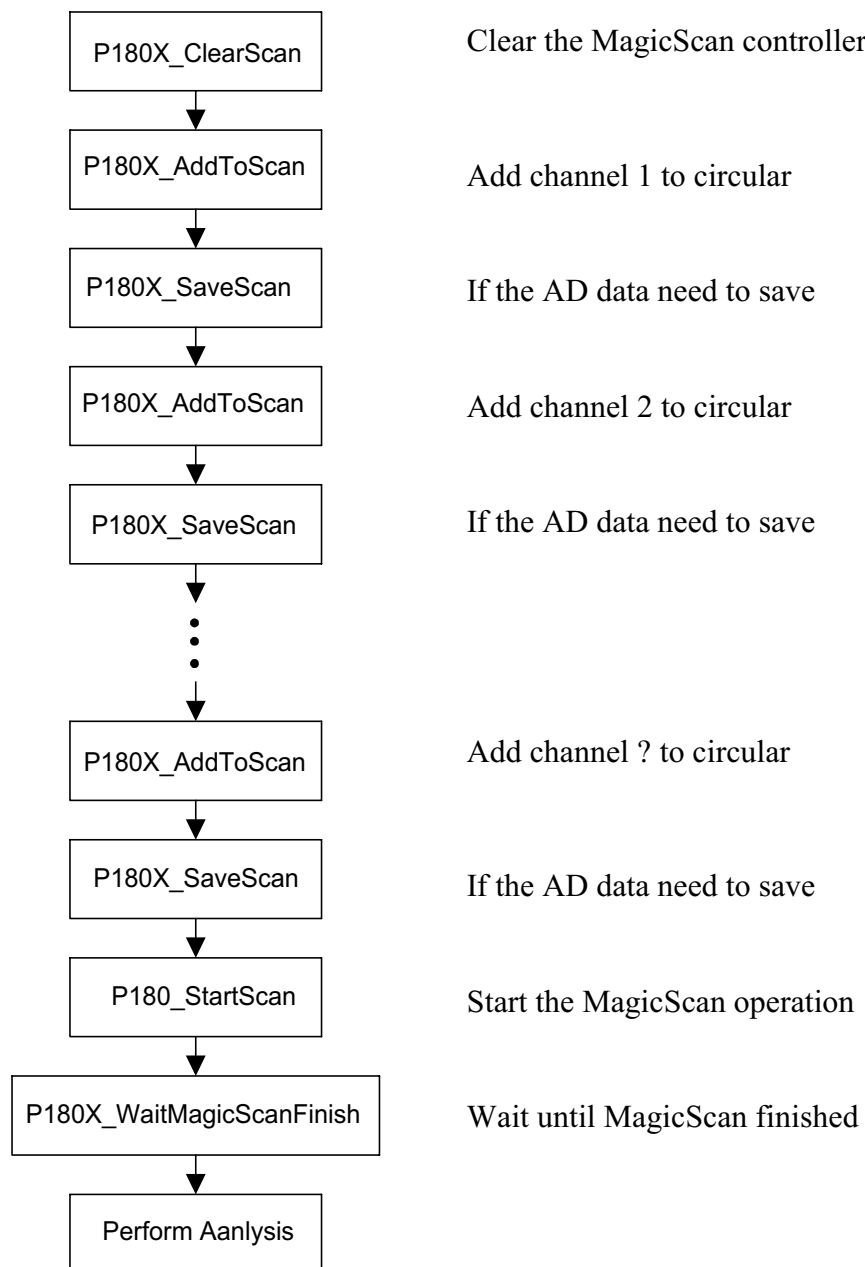
The **P180X\_SetChannelConfig** will activate the selected channel and its configuration code. Then the other functions will refer to that channel and configuration. The general flow chart is given as follows :



- **P1202\_SetChannelConfig(...)** is designed for **PCI-1202H/L**
- **P1602\_SetChannelConfig(...)** is designed for **PCI-1602 and PCI-1602F**

## 4.8 The MagicScan Mode AD Conversion

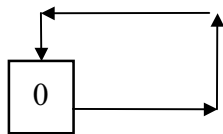
The **P180X\_ClearScan** will set the MagicScan controller to its initial state. The **P180X\_AddToScan** will add the channels to MagicScan circular queue one by one. **The order of P180X\_AddToScan is the scan order.** The maximum queue size is **48**. The scan order is random and can be repeat. The AD data will not save in the normal condition. The AD data of MagicScan can be saved in array if **P180X\_SaveScan** is used. The flowchart is given as follows:



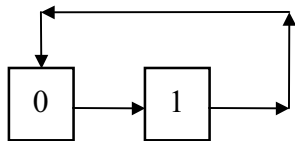
- **P1202\_ClearScan(...)** is designed for PCI-1202H/L
- **P1602\_ClearScan(...)** is designed for PCI-1602 and PCI-1602F

### 4.8.1 The MagicScan Circular\_Scan\_Queue

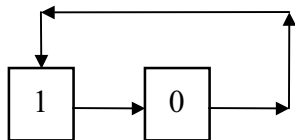
The MagicScan controller equips a **circular queue** for scan sequence control. The scan sequence is **one by one** and **repeatable** with the limitation of maximum 48 channels. So the following scan sequence are all validate :



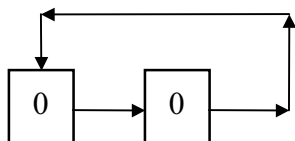
One channel MagicScan



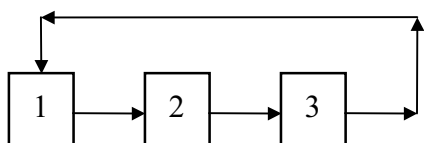
Two channels MagicScan, scan



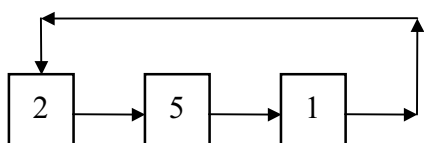
Two channels MagicScan, scan



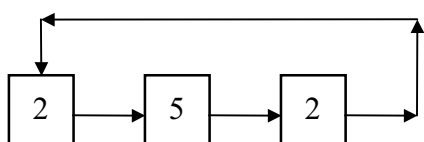
Two channels MagicScan, scan



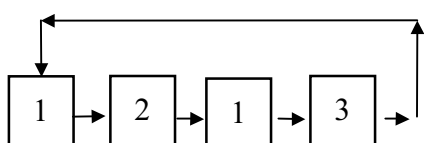
Three channels MagicScan : 123123123



Three channels MagicScan : 251251251



Three channels MagicScan : 252252252



Four channels MagicScan : 12131213

## 4.8.2 The Digital Filter of MagicScan

The digital filter is a **average** filter.

**Filter value** =  $(V_1+V_2+\dots+V_n)/n$ , where n is average factor

If the input signal is very noisy, this filter can be used to remove these noises.

---

## 4.8.3 The Different Sampling Rate of MagicScan

The MagicScan controller scan the analog inputs in **fixed-sampling-rate**. The **different sampling rate** is implemented with **averaging** technique. **This technique is the same as the digital filter** described in Sec. 4.8.2. If the user wish to use the different sampling rate, the digital filter will be active at the same time. **This is a situation of ALL or NO. You can use both the digital filter and the different sampling rate at the same time or use neither of them.**

```
P180X_ClearScan();
P180X_AddToScan(?,?,10,...); → only one channel scan
P180X_StartScan(?,24); → the AD sampling rate = 8M/24=333K
                        → the factor=10 → sampling rate=333K/10=33.3K
```

```
P180X_ClearScan();
P180X_AddToScan(A,?,1,...);
P180X_AddToScan(B,?,2,...);
P180X_AddToScan(C,?,3,...);
P180X_StartScan(?,24); → the AD sampling rate = 8M/24=333K
                        → scan sampling rate=333K/3=111K
channel_A sampling rate=111K/1=111K
channel_B sampling rate=111K/2=55.5K
channel_C sampling rate=111K/3=37K
```

- **P1202\_ClearScan(...)** is designed for PCI-1202H/L
- **P1602\_ClearScan(...)** is designed for PCI-1602 and PCI-1602F

## 4.8.4 The High/Low Alarm of MagicScan

There are 5 alarm types are given as follows:

**Type 0 : no alarm**

**Type 1 : high alarm** → any AD data > High\_alarm\_value

**Type 2 : low alarm** → any AD data < Low\_alarm\_value

**Type 3 : in alarm** → Low\_alarm\_value < any AD data < High\_alarm\_value

**Type 4 : out alarm** → any AD data < Low\_alarm\_value or  
any AD data > High\_alarm\_value

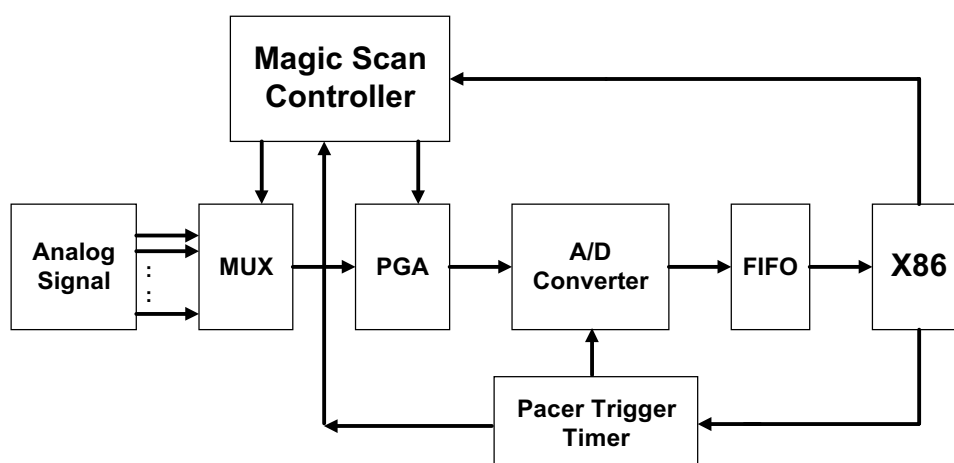
All the alarm\_value are defined in HEX format

## 4.8.5 The MagicScan Function

The features of MagicScan are given as follows:

1. Different gain for each channel
2. Non-sequential order for channel scan
3. Different sampling rate for each channel (use with digital filter)
4. Programmable different digital filter for each scan channel
5. Programmable HI/LO alarm for each channel
6. Three external trigger: post-trigger, pre-trigger and middle-trigger
7. Maintain at 330K max. for total channel scan
8. Easy programming

The MagicScan function is implemented with software and hardware. The feature 1 and feature 2 are implemented in hardware. The other features are implemented in software. The block diagram of MagicScan function is given as follows:



(1) The Magic Scan controller is a high performance RISC-like controller. It can scan the analog input signal in non-sequential order. It also control the PGA to different predefined gain for each channel.

(2) The pacer trigger timer will be generated the trigger signal to A/D converter.

(3) The A/D conversion data will enter the FIFO.

(4) The X86 will read and analyze the A/D data from FIFO while the CPU is ready. The FIFO is 1K for PCI-1800 and 2K or 8K for PCI-1802. The X86 will compute and analyze the A/D data while the A/D conversion is going. Therefore the speed of X86 must compatible with the speed of A/D conversion. The A/D conversion can be 330K max. in channel/scan mode. Therefore the X86 must handle 330K samples per second to avoid overflow. The Pentium-120 CPU or more powerful CPU is recommended.



The A/D conversion data in FIFO are in the same sampling rate (refer to (1), (2), (3)).

For example,

- the scan channel is 1 → 2 → 3
- the pacer sampling rate is 330K
- the expected sampling rate for channel 1 is 110K
- the expected sampling rate for channel 2 is 55K
- the expected sampling rate for channel 3 is 11K

The hardware will scan the analog data into FIFO as follows:

1,2,3,1,2,3,1,2,3,1,2,3,1,2,3,1,2,3.....

→ total 330K

→ every 1,1,1,1,1 is 110K

→ every 2,2,2,2,2 is 110K

→ every 3,3,3,3,3 is 110K

The software has to fetch the 2,2,2,2,2 in 55K, therefore the software average the continue two 2 into one 2 to get 55K as follows:

2,2, 2,2, 2,2, 2,2,  
2, 2, 2, 2, → 55K

The software has to fetch the 3,3,3,3,3 in 11K, therefore the software average the continue ten 3 into one 3 to get 11K.

There are very heavy computation load for the X86 to execute the MagicScan function. These computation loads are given as follows:

1. average the continue N data into one data to get different sampling rate data
2. compare each A/D data with the HI/LO alarm limit
3. save the A/D data into memory if the save flag is enable

The MagicScan function described in this section can be realized in Pentium-120 & Windows 95.

Refer to Sec. 4.8.6 for driver source.

Refer to Chapter 8 for demo program.

Refer to Chapter 10 for performance evaluation.

## 4.8.6 The MagicScan Thread

```
//-----  
// wThreadStatus : 0x01=MagicScan start  
//           0x02=timeout1  
//           0x04=timeout2  
//           0x08=FIFO overflow  
//           0x80=MagicScan OK  
  
WORD magic_scan()  
{  
WORD wVal,w1,w3;  
DWORD i,dwTime,j,k,dwIndex;  
  
for (j=0; j<wMP; j++) dwMagicSum[j]=0;  
for (j=0; j<wMP; j++) wMagicNow[j]=wMagicAve[j];  
for (j=0; j<wMP; j++) wMagicP[j]=0;  
for (i=0; i<wMP; i++) // skip the MagicScan settling time  
{  
dwTime=0;  
for (;;)   
{  
wVal=inport(wAddrCtrl)&0x20;  
if(wVal!=0) break;  
dwTime++;  
if(dwTime>100000)  
return TimeOut;  
}  
inport(wAddrAdda)&0xffff;  
}  
dwMagicLowAlarm=0;  
dwMagicHighAlarm=0;  
for(i=0; i<wMagicNum; i++)  
{  
for (j=0; j<wMP; j++)  
{  
dwTime=0;
```

```

for (;;)
{
wVal=inport(wAddrCtrl)&0x60;
if (wVal==0x20) return FifoOverflow;
if (wVal==0x60) break;
dwTime++;
if (dwTime>100000) return TimeOut;
}
dwMagicSum[j]+=(inport(wAddrAdda)&0x0fff); /* 0x0fff for 12-bitADC, 0xffff for 16-bit ADC */
wMagicNow[j]--;
w1=wMagicNow[j];
if (w1==0)
{
wVal=(WORD)(dwMagicSum[j]/wMagicAve[j]);
if (wMagicScanSave[j]==1)
{
*((wMagicScanBuf[j])+wMagicP[j])=wVal;
wMagicP[j]++;
}
w3=wMagicAlarmType[j];
if(w3>0) // 0 = no alarm
{
dwIndex=0x01; k=j;
while (k>0)
{
dwIndex=dwIndex<<1;
k--;
}
if (w3==2) // 2 = low alarm
{
if (wVal<wMagicLowAlarm[j]) dwMagicLowAlarm |= dwIndex;
}
else if (w3==1) // 1 = high alarm
{
if (wVal>wMagicHighAlarm[j]) dwMagicHighAlarm |= dwIndex;
}
else if (w3==4) // 4 = high or low alarm
{

```

```
    if (wVal<wMagicLowAlarm[j])  dwMagicLowAlarm |= dwIndex;
    if (wVal>wMagicHighAlarm[j]) dwMagicHighAlarm |= dwIndex;
    }
else if (w3==3) // 3 = in [low,high] alarm
    {
    if ((wVal>wMagicLowAlarm[j])&& (wVal<wMagicHighAlarm[j]))
        {
        dwMagicLowAlarm |= dwIndex;
        dwMagicHighAlarm |= dwIndex;
        }
    }
}
dwMagicSum[j]=0;
wMagicNow[j]=wMagicAve[j];
} // end if(w1
} // end for(j=
} // end for(i=
ret_label:
disable_timer0();
return 0;
}
```

# 5. M\_Function

Some real world applications have to send out the pre-defined pattern to the external device and measure the output responses for analysis. The user need one arbitrary wave form generator and one high speed A/D converter. **The M\_Functions, provided by PCI-1202/1602/1800/1802, can send out the user defined arbitrary waveform and perform the A/D conversion at the same time.**

Refer to application note EP001 for details. The application note EP001 , including 33 pages, can be divided into four parts. The introduction and common questions are given in part 1. The demo and analysis VIs for LabVIEW 4.0 are given in part 2. The function description and demo program for VC/C++ 4.0 are given in part 3. The usage for HP-VEE 3.21 is provided in part 4.

The M\_Functions can be executed under **DOS, Windows 3.1/95 and Windows NT.** Some programming languages(**VC++, BC++, VB, Delphi, BCB**) and package(**LabVIEW and more**) can call the M\_Functions now. The spectrum output response of the M\_FUN\_1 by LabView 4.0 is given as follows.

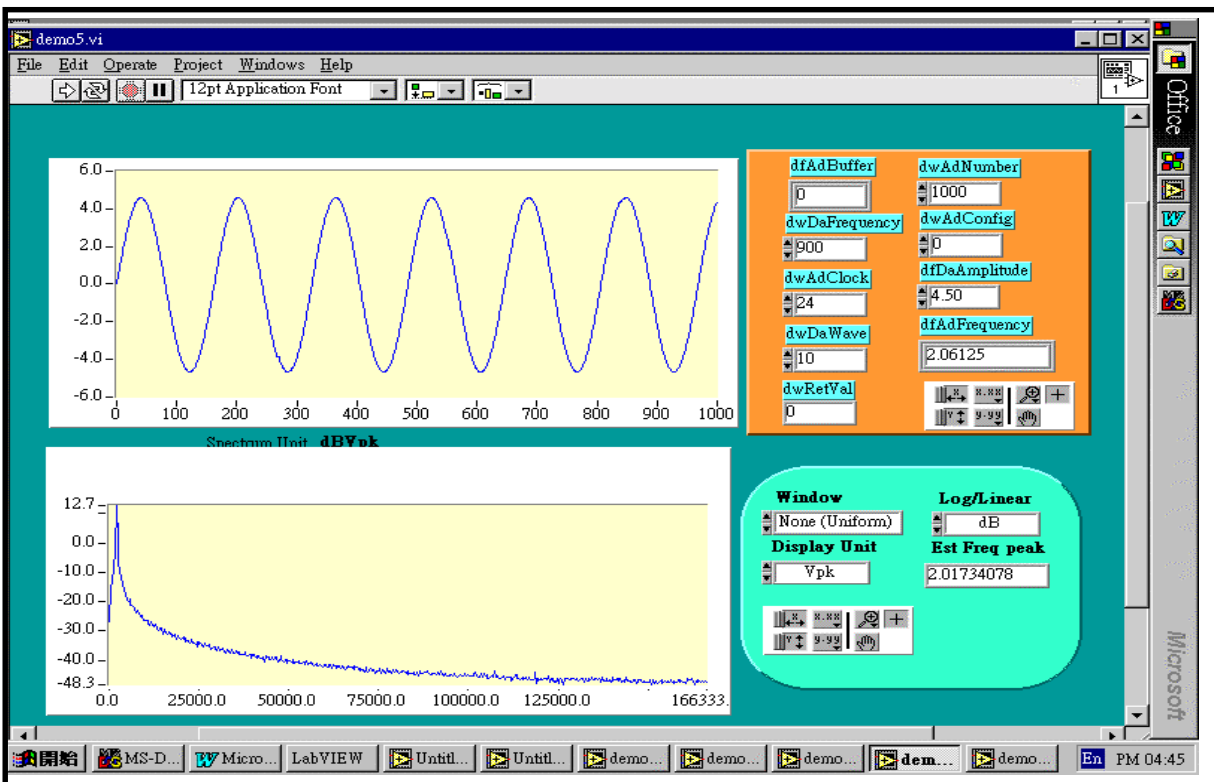


Figure 5-1: The spectrum output response of M-FUN\_1.

## 5.1 Introduction

### ● What Is M\_Functions?

The features of the M\_Functions are given as follows:

1. Arbitrary wave form generation from D/A output port (2 channels max.)
2. Perform MagicScan A/D conversion at the same time (32 channels max.)
3. Only one function call is needed
4. Very easy to use

The user can send out the D/A wave form output to the external device and measure the response(32 channels max.) at the same time. The block diagram of the M\_Functions is given as follows:

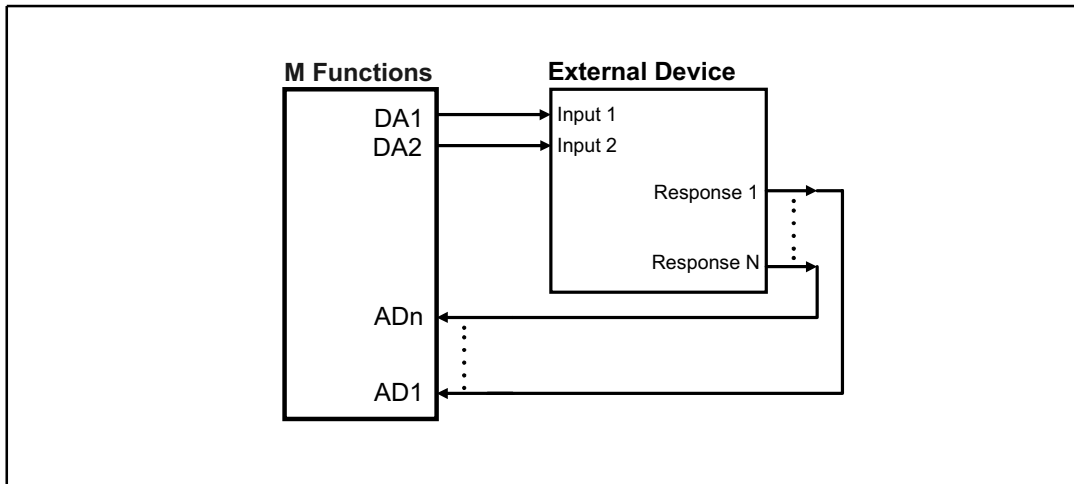


Figure 5-2: The block diagram of M-Functions.

### ● Which types of waveform can be generated by the M\_Functions ?

The M\_Functions use **wave-form-image-data** format to reconstruct the output waveform. Therefore nearly any types of waveform can be generated. The only limitations are resolution and frequency. It is very difficult to generate a very high resolution and high frequency waveform.

If the user want to generate the periodic wave form such as sine, cosine,...., the M\_Functions can provide the output wave form over 100K samples/sec. The +/- 5V 100Ks/s sine wave shown in Figure 5-3 and +/- 5V 200Ks/s sine wave shown in Figure 5-4 are all generated by M\_Function1. The Figure 5-3 and Figure 5-4 is measured by Tektronix TDS 220. The display resolution of TDS 220 is limited, so the output waveform does not look smooth. The real output waveform is smooth.

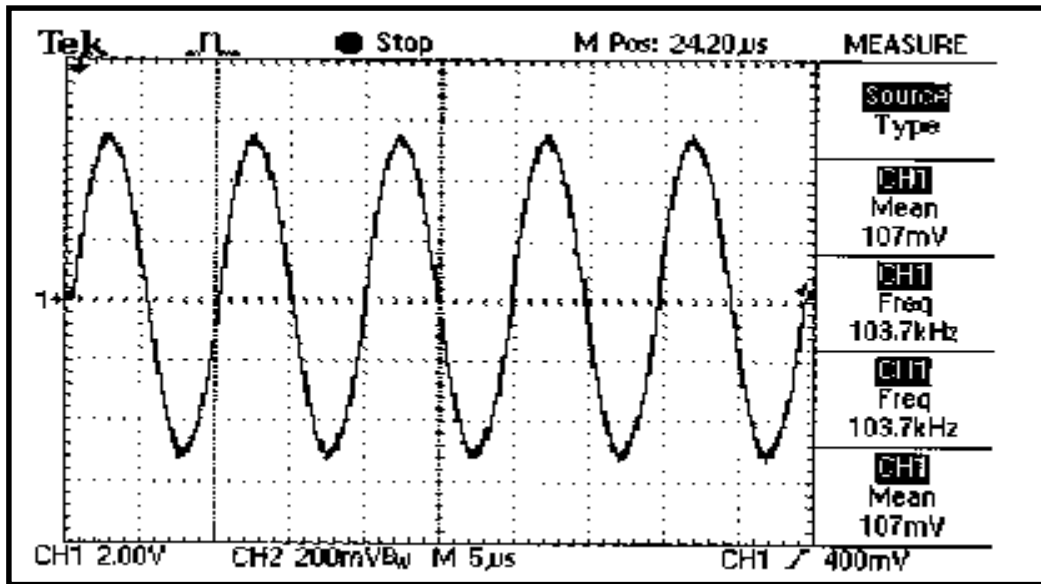


Figure 5-3: The M\_Function\_1 send out a 100K, +/- 5V sine wave.  
(measured by Tektronix TDS 220)

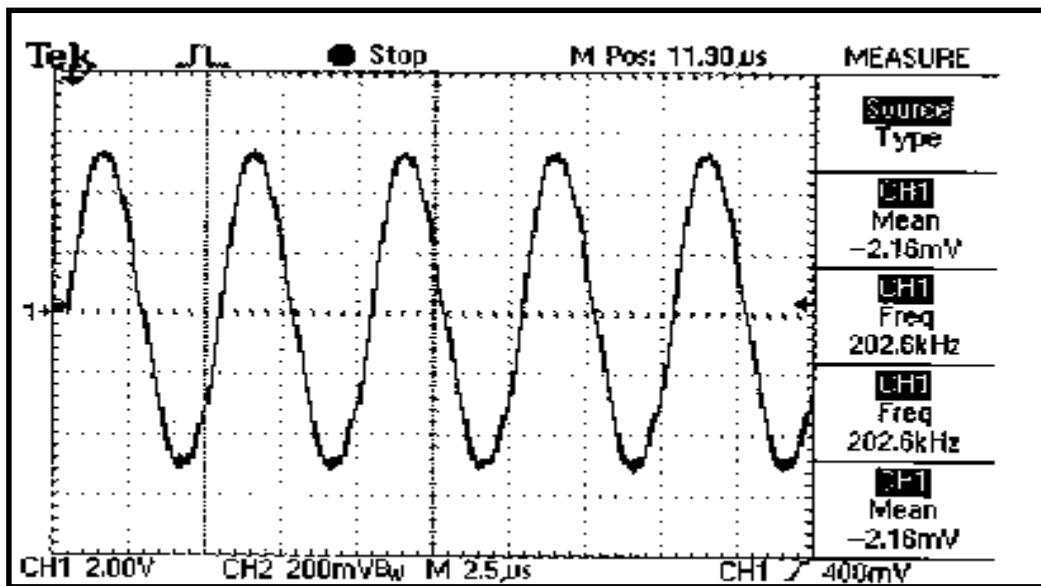


Figure 5-4: The M\_Function\_1 send out a 200K, +/-5V sine wave.  
(measured by Tektronix TDS 220)

---

● **How many M\_Functions are ready now ?**

There are four M\_Functions, P180X\_M\_FUN\_1, P180X\_M\_FUN\_2, P180X\_M\_FUN\_3 and M\_FUN\_4 are ready now. The M\_FUN\_1 will automatic to compute the sine wave output image. The M\_FUN\_2 is designed for arbitrary waveform generation, so the user can prepare their waveform for M\_FUN\_2. The M\_FUN\_3 is similar to M\_FUN\_1 except the A/D input channels are programmable. The comparison table is given as follows:

driver name	D/A	A/D
P180X_M_FUN_1	Channel_0, sine wave	channel_0, $\pm 10V$
P180X_M_FUN_2	Channel_0, arbitrary wave form	channel_0, $\pm 10V$
P180X_M_FUN_3	Channel_0, sine wave	channel/gain programmable (32 channels max.)
P180X_M_FUN_4	Channel_0, square wave or semi-square-wave or sine wave	channel/gain programmable (32 channels max.)

Because the M\_Functions are so powerful, we accept special design request (OEM or ODM). The user can e-mail the request to [icpdas@ms8.hinet.net](mailto:icpdas@ms8.hinet.net)

● **Which cards support the M\_Functions ?**

The PCI-1800H/L, PCI-1802H/L, PCI-1602, PCI-1602F and PCI-1202H/L can support M\_Functions now.

● **Which operating systems support the M\_Functions ?**

The M\_Functions can be executed under DOS, Windows 3.1/95/98, Windows NT 3.51/4.0 now.



● **Limitation**

The system will interrupt the driver software under Windows 95/NT. The partial function of D/A arbitrary waveform generation is implemented by software. Therefore the D/A output wave form will be distorted sometimes. Refer to Figure 5-5 for details.

If the user has to generate the periodic wave form such as sin, cos..., and the analysis is similar to spectrum analysis, this type of output distortion will cause little trouble. **The user can RUN the demo3.vi given in EP001 and select CONTINUE RUN. The D/A output maybe distorted but the spectrum response is still very stable.**

If the user use DOS, the D/A output waveform will not be distorted in any time.

The new version of hardware, PCI-1802 H/L, will be ready soon. This board will equips a large on-board memory for D/A output waveform image. The output waveform will be generated by hardware, so it will be continue and no-distortion.

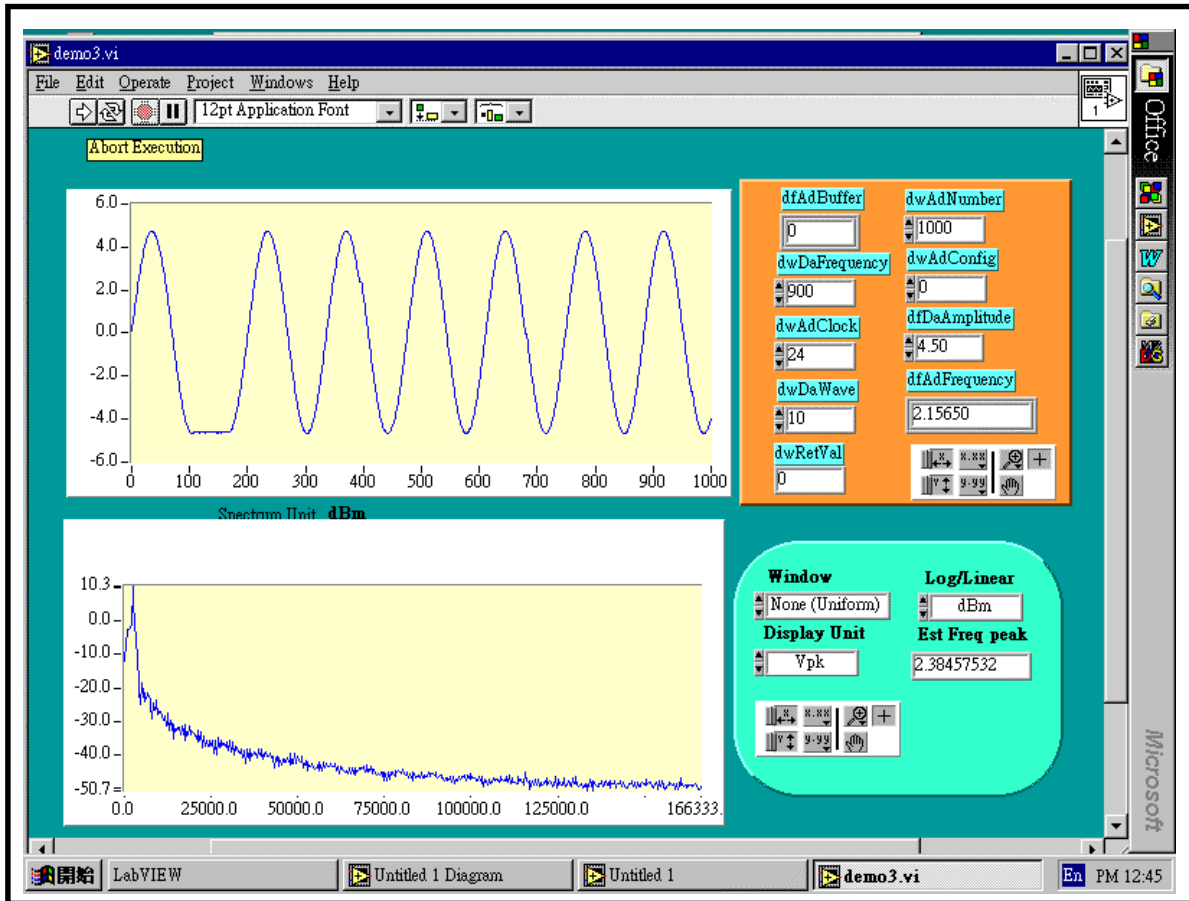


Figure 5-5: The D/A waveform is distorted but the spectrum response is nearly the same.

## 6. Continuous Capture Functions

The continuous capture functions are very useful in real world applications. It can be used many types of applications. Those applications are

1. Low speed, no storage, real-time processing, continuous capture
2. High speed, store the A/D data in PC main memory, time is limited by memory size  
(Referring to P180X\_FunA series functions and P180X\_FunB series function for more Detail information in 6.2)
3. High speed, store the A/D data in the external NVRAM, time is limited by memory size

---

### 6.1 General Purpose Driver

The PCI-1202/1602/1800/1802 is very suitable for these three applications. The software driver can support 16 cards max. in one PC system. The software of version 2.0 only support 2 cards for continuous capture function. The software 3.0 will support more cards. The continuous capture functions are special designed into many groups. Each group is corresponding to one card. There are three functions included in a group as follows:

1. P180X\_Card0\_StartScan(...)
2. P180X\_Card0\_ReadStatus(...)
3. P180X\_Card0\_StopScan(...)

Group-0: for card\_0 continuous capture function

1. P180X\_Card1\_StartScan(...)
2. P180X\_Card1\_ReadStatus(...)
3. P180X\_Card1\_StopScan(...)

Group-1: for card\_1 continuous capture function

The features of these functions are given as follows:

- Support DOS, Window 3.1/95/NT
- Single-card solution → group0, refer to DEMO13.C
- Multiple-card solution → group0 & group1 RUN at the same time, refer to DEMO14.C.
- Will support more cards in the next version software
- **P1202\_Card0\_StartScan(...)** is designed for PCI-1202H/L
- **P1602\_Card0\_StartScan(...)** is designed for PCI-1602 and PCI-1602F

The block diagram of continuous capture function is given as follows:

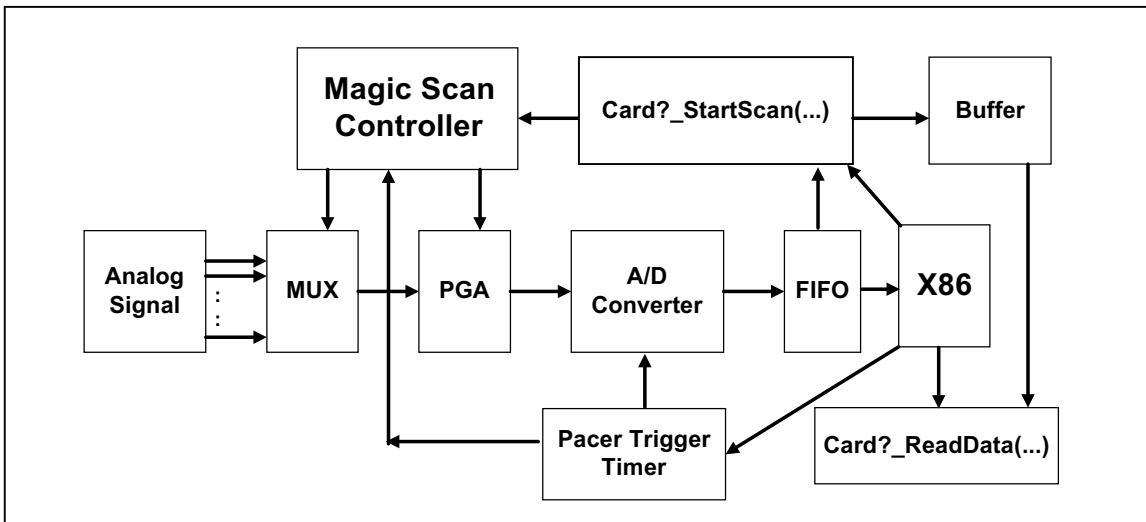


Figure 6-1: The block diagram of continuous capture.

- The P180X\_Card?\_StartScan(...) will perform the follows function:
  1. setup scan-queue
  2. setup channel/gain data
  3. setup continuous capture data
  4. create a multi-task thread for long time data acquisition
  5. If the group A/D data are ready → signal P180X\_Card?\_ReadStatus(...) to read data
- The P180X\_Card?\_ReadStatus(...) will read from the buffer prepared by P180X\_Card?\_StartScan(...). This function is running at the same time with the P180X\_Card?\_StartScan(...) thread. If the group A/D data is ready, the
- The P180X\_Card?\_StopScan(...) will stop all threads and return all resource

Note: The DOS & Windows 3.1 do not support multi-tasking. The software coding is a little different but the coding principle is the same.

- The sample program for **single board** is given as follows:

```
wRetVal=P180X_Card0_StartScan(.....);    // setup continuous capture function
                                           // this function will create thread

if (wRet != NoError)
{
    Show error message & return
}

// now the thread is active and the continuous capture function is going now
for(;;)
{
    wRetVal=P180X_Card0_ReadStatus(...);
    if (wRetVal != 0)
    {
        show these A/D data or
        save these A/D data or
        analyze these A/D data
    }

    if (stop flag is ON)    // for example, the user press STOP key here
    {
        Card0_StopScan(...);
        return OK
    }
}
```

- The sample program for **multi-boards** is given as follows:

```
wRetVal=P180X_Card0_StartScan(.....);    // setup continuous capture function
                                           // this function will create thread

if (wRet != NoError) { Show error message & return }

wRetVal=P180X_Card1_StartScan(.....);    // setup continuous capture function
                                           // this function will create thread

if (wRet != NoError) { Show error message & return }

wRetVal=P180X_Card?_SartScan(.....);    // setup continuous capture function
                                           // this function will create thread

if (wRet != NoError) { Show error message & return }

// now the thread is active and the continuous capture function is going now
for(;;)
```

```
{
wRetVal=P180X_Card0_ReadStatus(...);
if(wRetVal != 0)
    {
    show these A/D data or
    save these A/D data or
    analyze these A/D data
    }
wRetVal=P180X_Card1_ReadStatus(...);
if (wRetVal != 0)
    {
    show these A/D data or
    save these A/D data or
    analyze these A/D data
    }

wRetVal=P180X_Card?_ReadStatus(...);
if (wRetVal != 0)
    {
    show these A/D data or
    save these A/D data or
    analyze these A/D data
    }

if (stop flag is ON)    // for example, the user press STOP key here
    {
    Card0_StopScan(...);
    return OK
    }
}
```

Refer to DEMO13.C & DEMO14.C for details.

## 6.2 Save Data In PC Memory Driver

The P180X\_FunA & P180X\_FunB are series functions designed for continuous capture which storing the data into main memory. The features for these P180X\_FunA and P180X\_FunB are listed as follows:

- Sampling A/D data with high speed (for example, 330K)
- Continues capture for a long period (for example, 2.5 minutes continue)
- A/D data save in the PC memory first, then analyze these data later  
(memory size=330K\*60\*2.5=330K\*150=49.5M word=99M bytes)
- Refer to demo22.c for **330K, 2.5 minutes**, continuous capture **99M** bytes PC memory

The P180X\_FunA is designed for two board and the P180X\_FunB (Figure 6-2) is designed for single-board as follows:

P180X_FunA_Start P180X_FunA_ReadStatus P180X_FunA_Stop P180X_FunA_Get	<ul style="list-style-type: none"><li>● Support two board</li><li>● continuous capture</li><li>● data save in PC memory (can be as large as 256M)</li><li>● refer to demo20.c</li></ul>
P180X_FunB_Start P180X_FunB_ReadStatus P180X_FunB_Stop P180X_FunB_Get	<ul style="list-style-type: none"><li>● Support single board</li><li>● continuous capture</li><li>● data save in PC memory (can be as large as 256M)</li><li>● refer to demo21.c</li></ul>

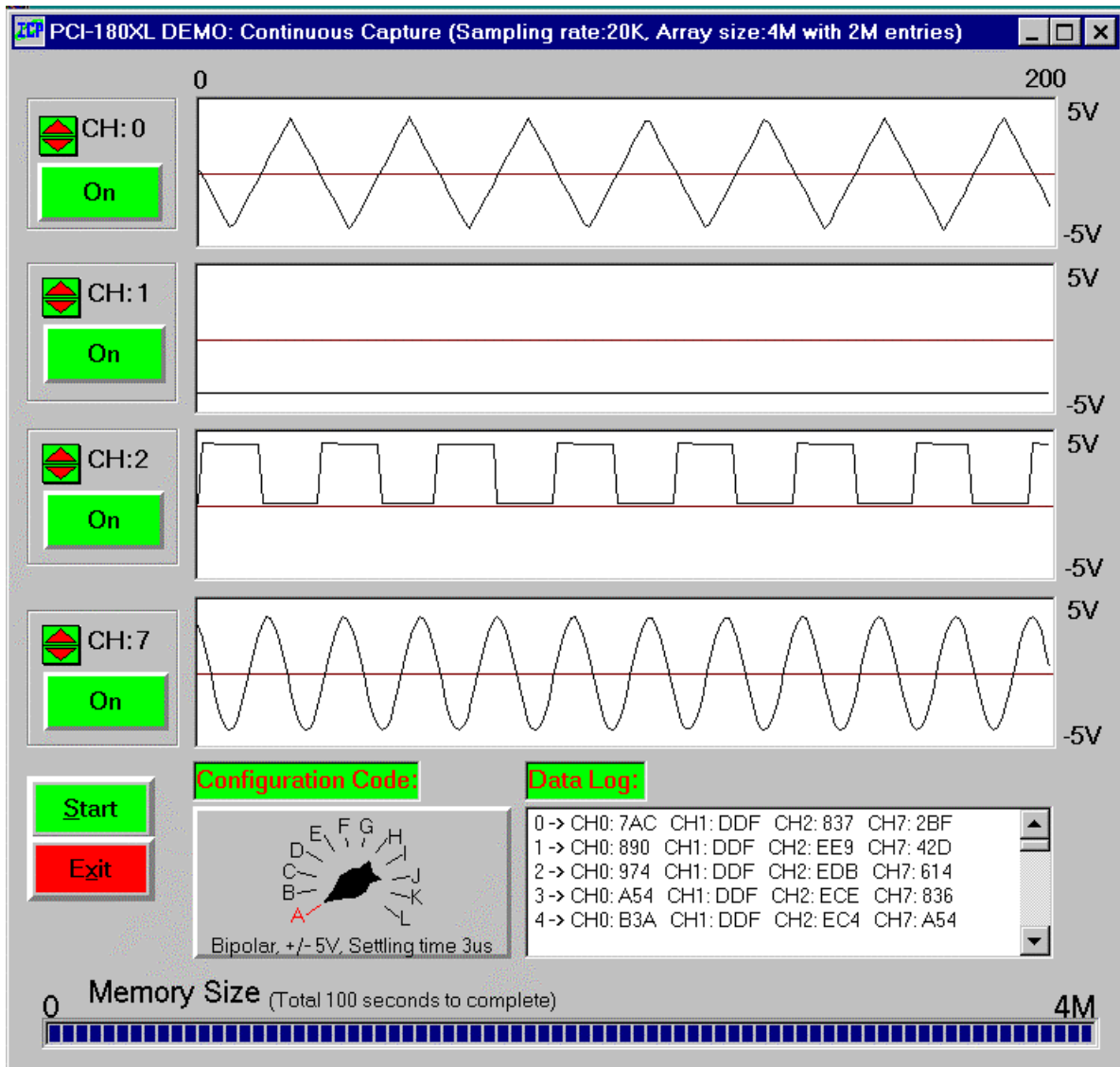


Figure 6-2. The Continuous Capture example.

# 7. Calibration

## 7.1 AD Calibration

- For PCI-1202/1800/1802

Step 1: Apply 0V to channel 0

Step 2: Apply 4.996V to channel 1

Step 3: Apply +0.6245V to channel 2 for PCI-1202(L)/1800(L)/1802(L)

Step 4: Apply +4.996mV to channel 2 for PCI-1202(H)/1800(H)/1802(H)

Step 5: Run DEMO19.EXE

Step 6: Adjust VR101 until CAL\_0 = 7FF or 800

Step 7: Adjust VR100 until CAL\_1 = FFE or FFF

Step 8: Repeat Step6 & Step7 until all OK

Step 9: Adjust VR1 until CAL\_2 = FFE or FFF

Step 10: Adjust VR2 until CAL\_3 = 000 or 001

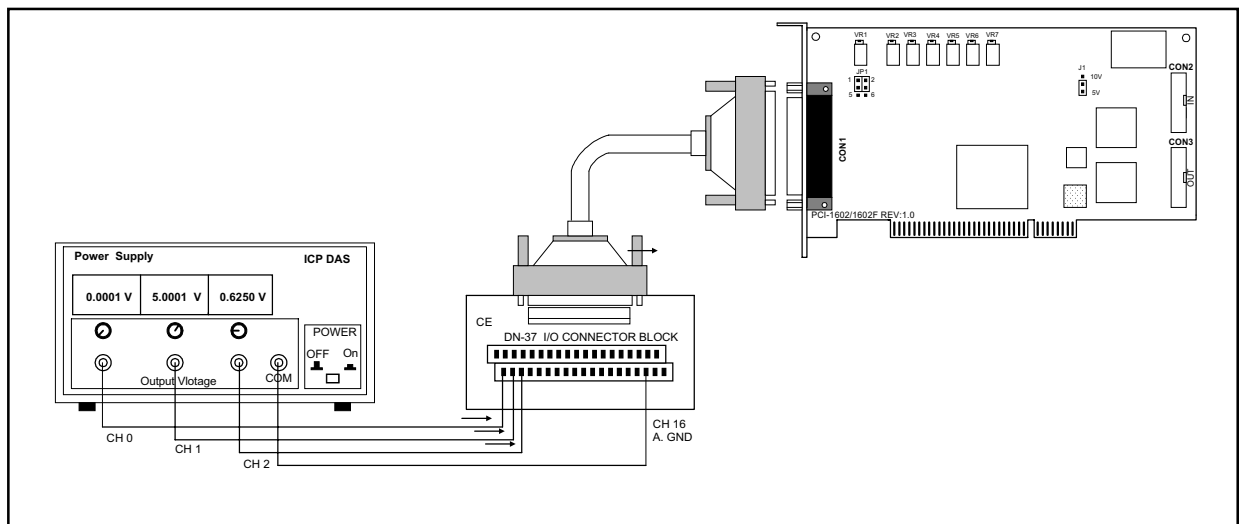


Figure 7-1. AD Calibration

**Note: The CH 16 is the GND of analog signal for PCI-1202/1602.1802 card  
The CH 9/10 are the GND of analog signal for PCI-1800 card**



- For PCI-1602/1602F

Step 1: Apply 0V to channel 0

Step 2: Apply 4.996V to channel 1

Step 3: Apply +0.6245V to channel 2

Step 4: Run DEMO19.EXE

Step 5: Adjust VR3 until channel 0 = 0000 or FFFF

Step 6: Adjust VR2 until channel 1 = 7FFF or 7FFE

Step 7: Repeat Step5 & Step6 until all OK

Step 8: Adjust VR1 until channel 2 = 0FFC or 0FFD

## 7.2 D/A Calibration

- For PCI-1800/1802 version\_F & PCI-1202

Step 1: J1 select +10V

Step 2: Connect the D/A channel 0 to voltage meter

Step 3: Send 0x800 to D/A channel 0

Step 4: Adjust VR200 until voltage meter = 0V

Step 5: Send 0 to D/A channel 0

Step 6: Adjust VR201 until voltage meter = -10V

Step 7: Connect the D/A channel 1 to voltage meter

Step 8: Send 0x800 to D/A channel 1

Step 9: Adjust VR202 until voltage meter = 0V

Step 10: Send 0 to D/A channel 1

Step 11 : Adjust VR203 until voltage meter = -10V

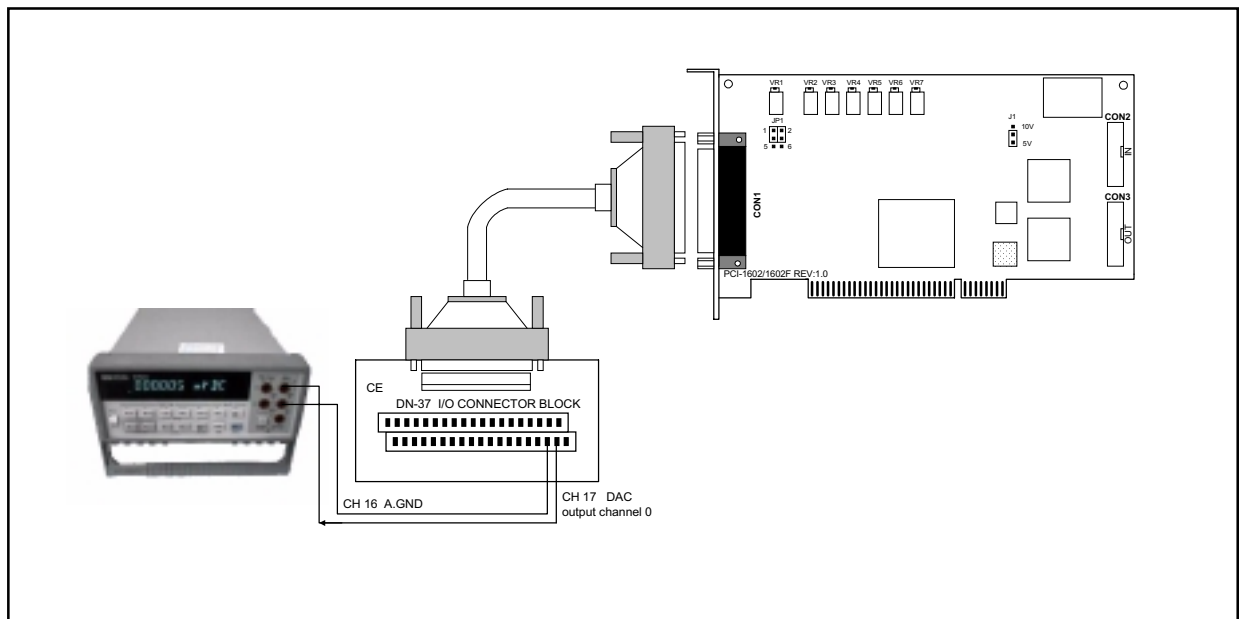


Figure 7-2. D/A Calibration

**Note: The CH 18/36 are the output channels 0/1 of DAC for PCI-1202/1602.1802 card  
The CH 30/32 are the output channels 0/1 of DAC for PCI-1800 card**

- For PCI-1800/1802 version\_C

Step 1: J1 select +10V

Step 2: Connect the D/A channel 0 to voltage meter

Step 3: Send 0 to D/A channel 0

Step 4: Adjust VR3 until voltage meter = -10V

- For PCI-1602

Step 1: J1 select +10V

Step 2: Connect the D/A channel 0 to voltage meter

Step 3: Send 0x800 to D/A channel 0

Step 4: Adjust VR4 until voltage meter = 0V

Step 5: Send 0 to D/A channel 0

Step 6: Adjust VR5 until voltage meter = -10V

Step 7: Connect the D/A channel 1 to voltage meter

Step 8: Send 0x800 to D/A channel 1

Step 9: Adjust VR7 until voltage meter = 0V

Step 10: Send 0 to D/A channel 1

Step 11: Adjust VR6 until voltage meter = -10V

## 8. Software and Demo Program

The software drivers can be classified as follows:

- NAPPPI/dos: huge and large mode library for TC, MSC and BC
- NAPPPI/w31: DLLs for VC++, VB
- NAPPPI/win: DLLs for VC++, BC++, VB, Delphi, BCB, LabVIEW
- NAPPPI/wnt: DLLs for VC++, BC++, VB, Delphi, BCB, LabVIEW

There are about 20 demo program given as follows:

- demo1: one board, D/I/O test, D/A test, A/D polling test, general test
- demo2: two board, same as demo1
- demo3: one board, A/D by software trigger(polling) and A/D by pacer trigger demo
- demo4: two board, same as demo3
- demo5: one board, M\_function\_1 demo
- demo6: two board, same as demo5
- demo7: one board, M\_function\_2 demo
- demo8: two board, same as demo7
- demo9: one board, M\_function\_3 demo
- demo10: two board, same as demo9
- demo11: one board, MagicScan demo
- demo12: two board, same as demo11
- demo13: one board, continuous capture demo
- demo14: two board, continuous capture demo
- demo15: all installed board, D/I/O test for board number identification
- demo16: one board, performance evaluation demo
- demo17: one board, MagicScan demo, scan sequence: 1→2→0
- demo18: one board, MagicScan demo, scan 32 channel, show channel 0/1/15/16/17
- demo19: one board, A/D calibration.
- demo20: two board, P180X\_FUNA, continuous capture demo
- demo21: single board, P180X\_FUNB, continuous capture demo
- demo22: single board, P180X\_FUNB, 330K, 2.5 min, continuous capture 99M bytes
- demo23: single board, post-trigger demo
- demo24: single board, pre-trigger demo
- demo25: single board, middle-trigger demo
- demo26: single board, pre-trigger demo for version-C

- demo27: single board, middle-trigger demo for version-C
- demo28: multi-task, critical section driver demo
- demo29: testing for MagicScan controller.
- demo30: testing for Pacer Trigger.
- Demo31: testing for Polling.
- Demo32: monitoring the incoming data from MagicScan, then set a digital out bit on when  
the incoming data exceed a defined threshold.
- Demo33: MagicScan total sample rate=176k/sec for 8 channels.
- Demo34: continuous capture scan total sample rate=33.3K/sec for 32 channels and save to disk.



## 9.3 D/O Test

Step 1: Power-off PC

Step 2: Install one PCI-1202/1602/1800/1802 card with a 20-pin flat cable between CON1 & CON2

Step 3: Power-on PC, run DEMO15.EXE

Step 4: Check the value of D/O and D/I → must be the same.

---

## 9.4 D/A Test

Step 1: Power-off PC

Step 2: Install one PCI-1202/1602/1800/1802 card with DA channel 0 connected to A/D channel 0.

Step 3: Power-on PC, run DEMO1.EXE

Step 4: Check the value of A\_0 → = 1.25 volt.

Step 5: Run DEMO5.EXE

Step 6: Check the wave form shown in screen must be sine wave

---

## 9.5 A/D Test

Step 1: Power-off PC

Step 2: Install one PCI-1202/1602/1800/1802 card with DA channel 0 connected to A/D channel 0.

Step 3: Power-on PC, run DEMO1.EXE

Step 4: Check the value of A\_0 → = 1.25 volt.

Step 5: Run DEMO5.EXE

Step 6: Check the waveform shown in screen must be sine wave

Step 7: Apply analog signals to all A/D channels

Step 8: Run DEMO3.EXE to check all A/D data measured

## 10. Performance Evaluation

Demo Program	Performance	Description
DEMO16.EXE.	1.7M s/s	D/I performance
DEMO16.EXE.	2.1M s/s	D/O performance
DEMO16.EXE.	2.0M s/s	D/A performance
DEMO13.EXE	20K s/s	Continuous capture function, one card, two channels Total=20K s/s → 10K s/s per channels
DEMO14.EXE	20K s/s	Continuous capture function, two card, two channels Total=20K s/s → 10K s/s per channels
DEMO5.EXE	20K sine max.	M_function demo, D/A channel_0 to A/D channel_0 20K Hz sine wave max. 20 Hz sine wave min.
DEMO11.EXE	330K 110K 200K 100K	MagicScan demo for PCI-1800/1802 MagicScan demo for PCI-1202 MagicScan demo for PCI-1602F MagicScan demo for PCI-1602

Note:

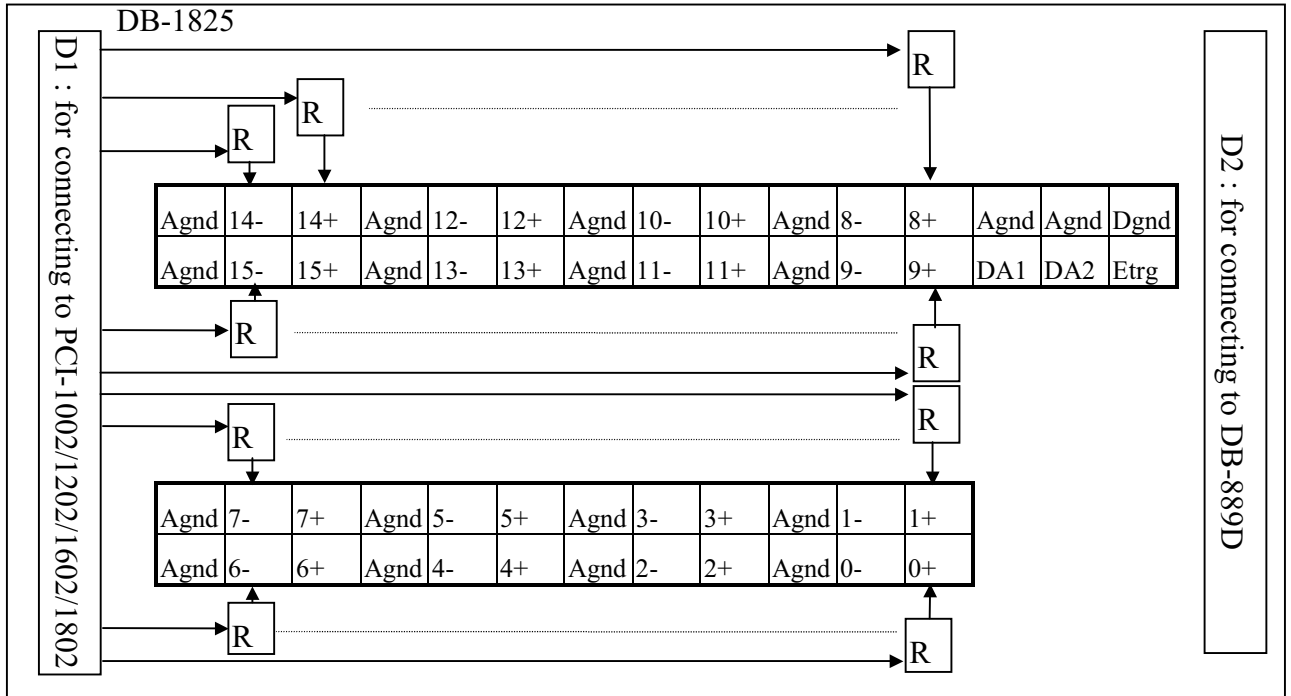
1. s/s → samples/second
2. All test are under Windows 95 and Pentium-200 CPU



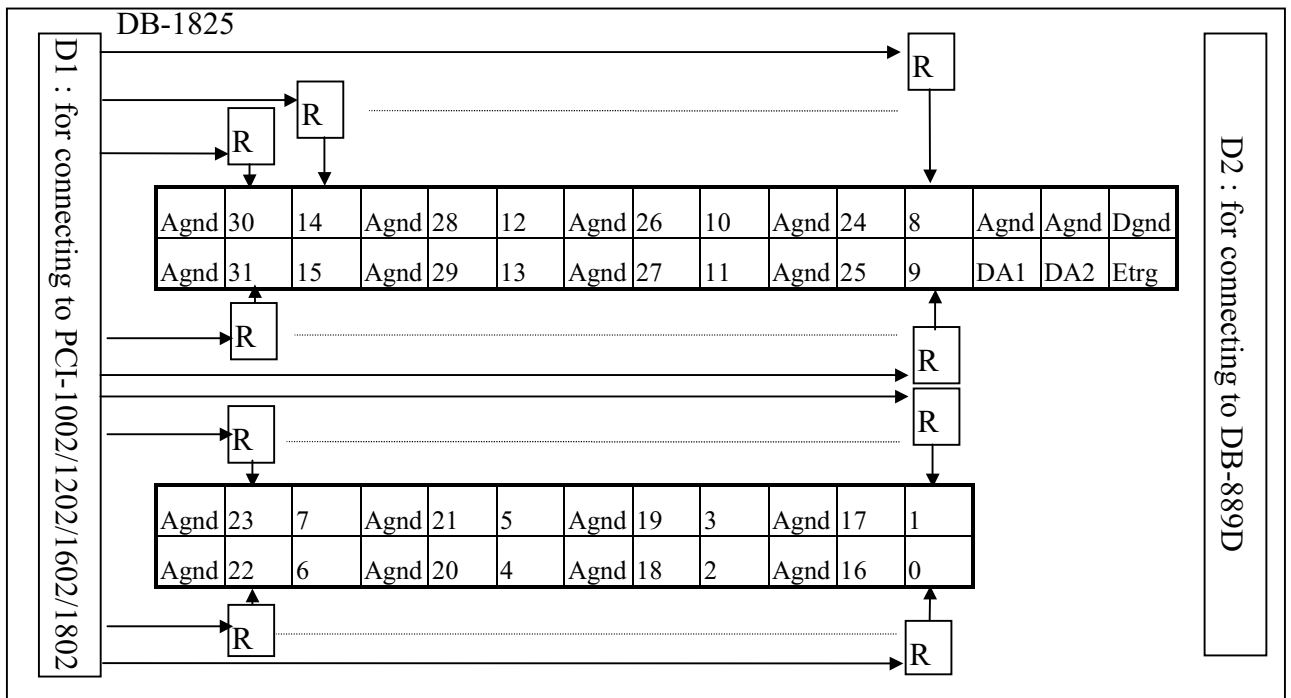


**A.2 : PCB layout for connecting to PCI-1002/1202/1602/1802:**

For differential input (R=0 ohm)



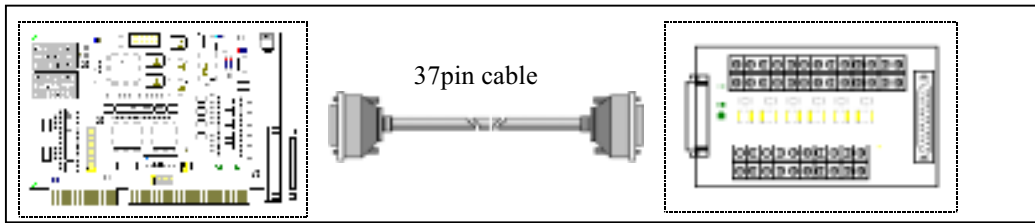
For single-ended input (R=0 ohm)



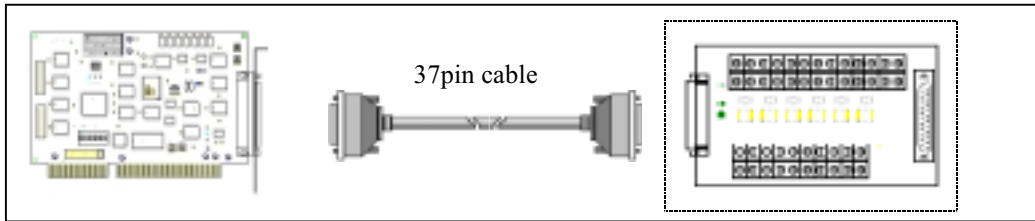
Pin assignment of D1 same as **CON3 of PCI-1002/1202/1602/1802**

Pin assignment of D2 same as **CN1 of DB-889D**

**A.3 : connection to ISO-AD32**



**A.4 : connection to PCI-1002/1202/1602/1802**



**A.5 : connection to PCI-1x02 and multiple DB-889D(16 channels differential)**

